

30 yıl

it baran
ticaret

www.baranticaret.com

2014 ÜRÜN KATALOĞU
PRODUCT CATALOGUE



it **baran**
b **ticaret**



Enituice

Standard Pensler

CNC Kayar Otomat Pensleri

Karbür Yataklama Pensleri

Özel Pensler

Doğru Seçim
Profesyonellik
Kalite



ISO9001:2008

2013 Yılında tam 30 yıldır size hizmet vermekte olan firmamız 1983 yılında Karaköy Perşembe Pazarı'nda kurulmuş, 2006 yılından bu yanada İmes Sanayi Sitesi'nde hizmetine devam etmektedir.

1983 Yılından bu yana sanayide kullanılan kesici takımlar, tutucu takımlar, Rovolver - Otomat ve CNC de kullanılan pensler, dış kontrol masterları, talaşlı imalatta kullanılan H tipi taraklar, pafta ve kılavuzlar, matkap uçları, torna katerleri ve sert metal uçları gibi 3500'ü aşkın ürün çeşidi ile müşterilerine hizmet vermektedir.

Firmamız yine aynı konuda tüketici tarafından kabul görmüş yüksek kaliteli otomat rolover tezgahı mandalları üretiminde yapmaktadır.

Müşteri hizmeti, ürün çeşitliliği ve ürün stoğu ile sektöründe istikrarlı bir çizgiye sahip olan **baran ticaret**, müşterisini doğru bilgilendiren ve müşteri ilişkilerinde sürekliliği esas alan deneyimli bir kuruluştur.

baran ticaret etik ve güvene dayalı ticari anlayışı, istikrar ve süreklilik arz eden çizgisiyle ve teknik bilgi ile desteklenen müşteri memnuniyetini esas alan çalışma prensipleriyle sizlere hizmet vermeye devam edecektir.

**Enituice****f. britsch**

baran ticaret was founded in Karaköy-Perşembe Pazarı in 1983 and has moved İmes Industrial Trading Centre in 2006. We are celebrating our 30th anniversary and take pride in providing the best service to our customers.

We are specialized in dealing with sensitive industrial cutting and holding tools. Collets, Gauges, Chasers, Dies, Taps, Diamond bits, and Drilling bits have been our main selected lines with over 3500 pcs items Since 1983.

baran ticaret is also founder of a well established firm called Ropesan created in 1988 which manufactures collets for Automatic Lathe, Turret Lathe and Cnc machinery. We carry on the whosale and retail distribution of Ropesan successfully. In addition to the same line, we have our own brand of Chuck Lever which are used for Automatic Lathe and Turret Lathe machinery.

Our target is simple; providing the best technical service based on our experience and satisfying costumers with the range of our stock. This has always been our aim for last 30 years.

Standard Pensler2-4**CNC****Kayar Otomat Pensleri**5-8**CNC****Kayar Otomat****Karbür Yataklama Pensleri**9 - 12**040 LINE****Kesme-Kanal-Tornalama Uçları****ve Katerler**13-22**140 LINE****Kesme-Kanal-Tornalama Uçları****ve Katerler**23-27**240 LINE****Kesme-Kanal Uçları ve****Katerler**28-29**400 LINE****Kesme-Kanal-Tornalama Uçları****ve Katerler**30-34**800 LINE****Kesme-Kanal-Tornalama Uçları****ve Katerler**35-41**800 LINE +****Kesme-Kanal-Tornalama Uçları****ve Katerler**42-43**MULTITURN-DEC-VPGT****Tornalama Uçları ve Katerler**44-45**OXOLINE 1000****Kesme-Kanal-Tornalama Uçları****ve Katerler**46-53**OXOLINE 1100****Kesme-Kanal-Tornalama Uçları****ve Katerler**54-55**Tırtıl ve Katerler**56**Karbür Otomat Kalemleri**57

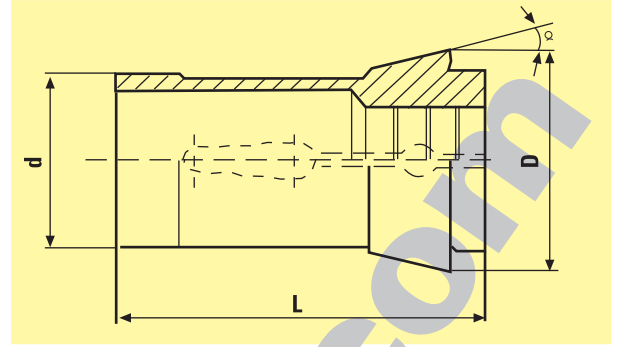

Standard Pensler

DIN	Model	Sipariş No	d	L	D	DIN No	Schau No	NEU NO
140E	TRAUB A-15	1215	Ø 22.0	55	Ø 30.0	6343-22	F22/71	
148E	TRAUB A-20	1220	Ø 28.0	70	Ø 38.0		F28/93	231.004
161E	TRAUB A-25	1225	Ø 32.0	75	Ø 45.0	6343-32	F32/221	231.005
162 E	INDEX# 25	1226	Ø 35.0	70	Ø 43.0		F35/67	
163 E	INDEX# 30	1230	Ø 35.0	80	Ø 48.0	6343-35	F35/94	
164 E	# 22 B&S LICO#32	1232	Ø 38.1	108	Ø 49.0		F38/72	285.002
171 E	INDEX# 36	1236	Ø 42.0	94	Ø 55.0	6343-42	F42/99	231.007
173 E	INDEX# 42	1242	Ø 48.0	94	Ø 60.0	6343-48	F48/81	231.009
177 E	INDEX# 52	1252	Ø 58.0	94	Ø 70.0			
185 E	INDEX# 60	1261	Ø 66.0	110	Ø 84.0	6343-60	F66/359	231.001
193 E	INDEX# 80	1280	Ø 90.0	130	Ø 107.0	6343-80		
POLYGYM	# 38	1238	Ø 42.0	92	Ø 51.0			
LI CO	TNS-30/42	1240	Ø 46.0	65	Ø 55.0			
	# 65	1265	Ø 72.0	142	Ø 90.25			
JINN FA	C-32	1332	Ø 40.0	104	Ø 54.5			
	C-44	1342	Ø 54.0	87	Ø 68.0			
	JCL-50	1350	Ø 60.0	89	Ø 72.0			
	JCL-60	1360	Ø 75.0	100	Ø 93.0			
	JCL-75	1375	Ø 85.0	110	Ø 98.0			
MIYNO	BNC20	1721	Ø 27.0	73	Ø 38.0			
	BNC34	1734	Ø 44.4	108	Ø 54.2			
	# 25	1725	Ø 40.0	95	Ø 45.0			
RIKEN	SAD-25	1726	Ø 30.0	66	Ø 43.0			
	SAD-40	1742	Ø 48.0	84	Ø 66.0			
	SAD-50	1750	Ø 56.0	94	Ø 68.0			
	SAD-65	1765	Ø 75.0	100	Ø 93.0			

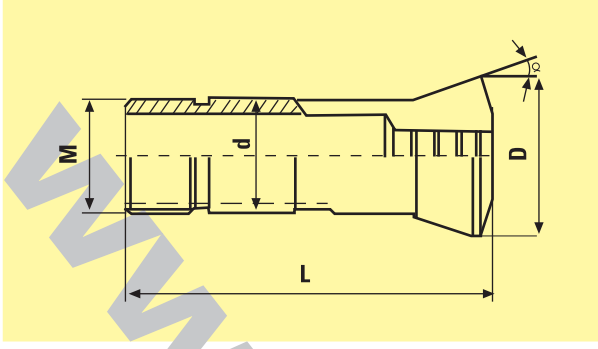

Standard Pensler

Tezgah	Model	Malzeme		d	L	D	Diş M
		Çelik	Karbür				
		Sipariş No	Sipariş No				
EGURO	#6	1015	2015	Ø 19.0	76	Ø 26.0	18.5 X 1.2
	#8	1020	2020	Ø 25.0	102	Ø 33.0	24 X 1.5
	#10	1024	2024	Ø 32.0	118	Ø 42.0	32 X 1.5
YUNG HO	YB-25	1025	2025	Ø 32.0	104	Ø 39.0	31.5 X 20f"
	YB-32	1032	2032	Ø 39.0	119	Ø 49.0	38 X 18f"
	YB-42	1042	2042	Ø 52.0	137	Ø 64.0	50 X 16f"
FUJI	#0825	1112	2112	Ø 16.0	72	Ø 24.0	15 X 0.85
	#1820	1120	2120	Ø 28.0	100	Ø 36.0	25 X 1.5
	#1825	1125	2125	Ø 35.0	124	Ø 49.0	33 X 1.5
	#1832	1132	2132	Ø 43.0	137	Ø 57.5	40 X 1.75
DAIWA	# 10	1410	2410	Ø 15.0	60	Ø 21.0	15 X 1.0
	#102	1412	2412	Ø 17.0	69	Ø 24.0	17 X 1.0
	#15	1415	2415	Ø 22.0	85	Ø 28.0	21 X 1.0
KITAMURA	XKNC-15FA	1515	2515	Ø 19.05	76	Ø 26.0	18.5 X 1.25
	XKNC-20FA	1520	2520	Ø 26.0	92	Ø 34.0	25 X 1.25
HARDINGE	5C	1705	2705	Ø 31.75	88	Ø 37.3	31.3 X 20f"
	16C	1716	2716	Ø 48.0	114.5	Ø 57.4	47.5 X 1.75
	20C	1720	2720	Ø 60.4	163	Ø 73.2	60 X 1.5
	2J	1702	2702	Ø 1.625"	3.250"	Ø 2.05"	1.611" X 18f"
	3J	1703	2703	Ø 2.000"	3.750"	Ø 2.41"	1.988" X 20f"
	22J	1722	2722	Ø 2.562"	4.000"	Ø 2.97"	2.550" X 18f"
RIKEN	PULL-25	1826	2826	Ø 36.0	88	Ø 44.0	32 X 1.5
	PULL-40	1840	2840	Ø 55.0	110	Ø 66.0	50 X 1.5
	PULL-60	1860	2860	Ø 83.0	132	Ø 97.0	78 X 2.0
CITIZEN	BL20/25	1820	2820	Ø 33.0	100	Ø 41.0	32 X 1.5
TSUGAMI	BM-16	1616	2616	Ø 30.0	75	Ø 38.0	25 X 1.5
STAR	SC-20	1920	2920	Ø 30.0	79	Ø 38.0	26 X 1.5
KATAMAZ	850	8024	2024	Ø 37.0	101	Ø 46.5	32 X 1.5
WACHIGAL	WPL-17	1517	2517	Ø 23.0	97	Ø 32.0	22 X 1.5
Wang Tzyy	#20	1320	2320	Ø 28.0	82	Ø 38.0	24 X 20f"

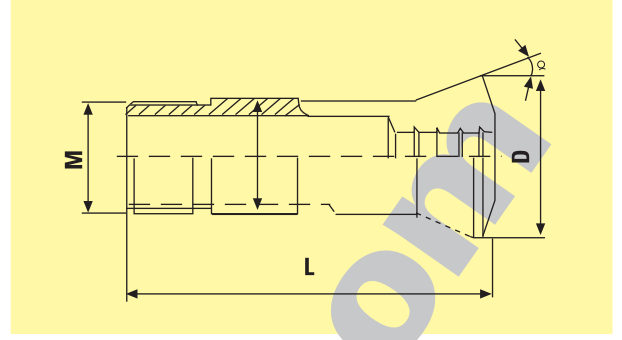

Standard Pensler

Tezgah	Model	Çelik	Karbür	d	L	D	Diş M
		Sipariş No	Sipariş No				
SENDAY	SD-25	1525	2525	Ø 34.0	84	Ø 41.5	29 X 20f"
	SD-32	1532	2532	Ø 42.0	95	Ø 49.0	38 X 20f"
	SD-34	1534	2534	Ø 42.0	95.5	Ø 51.0	36 X 1.5
	SD-45	1545	2545	Ø 56.0	120	Ø 68.0	51 X 20f"
	SD-52	1552	2552	Ø 61.0	120	Ø 68.0	56 X 20f"
SCHAUBLIN	W-20 80/00004	1620	2620	Ø 20.0	73	Ø 26.3	S 19.7X1.666
	W-25 80/00005	1625	2625	Ø 25.0	97.6	Ø 33.7	S 24.7X15f"
	HW-25 80/02010	1626	2626	Ø 25.0	97.6	Ø 33.7	S 24.7X15f"
	HB-32 72/02010	1632	2632	Ø 32.0	106	Ø 40.0	S 29.7X15f"
	L-20 77/00122	1613	2623	Ø 20.0	122	Ø 28.0	S 19.7X2.0
	B6 72/00128	1606	2606	Ø 6.0	31.3	Ø 10.5	5X36f"
	B8 72/00137	1608	2608	Ø 8.0	35.5	Ø 13.0	6.82X0.625
B46 72/02007	1246	2246	Ø 46.0	120	Ø 60.3	40X1.5L	
NANN	359 E (K23)	1923	2923	Ø 23.0	94	Ø 32.0	Tr23X1.5
	386 E (K32)	1932	2932	Ø 32.0	114	Ø 45.0	Tr32X1.5
	389 E (K45)	1945	2945	Ø 45.0	145	Ø 60.0	Tr45X2.0
	9049E	1246	2246	Ø 46.0	120	Ø 60.3	40X1.5L
	9070E	1940	2940	Ø 53.0	136	Ø 69.3	47X1.5L
	3640E(2)	1626	2626	Ø 25.0	97.6	Ø 33.7	S 24.7X15f"
	3714E	1632	2632	Ø 32.0	106	Ø 40.0	S 29.7X15f"
	3718E	1718	2718	Ø 32.0	124	Ø 45.0	Tr32X1.5
Davenport	Burring	1921	2921	Ø 1.060"	4.375"	Ø 1.190"	1.048"X16LH
	Serro B	1925	2925	Ø 1.218"	4.38"	Ø 1.5"	1.143"X16RH

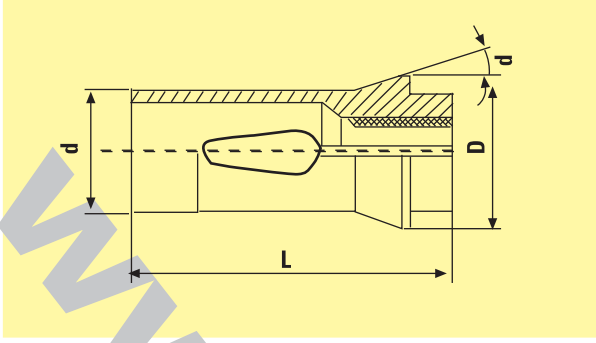

CNC Kayar Otomat Pensleri

Tezgah	Model	Karbür		Çelik		d	L	D	Muadil No			
		Sip. No	Sip. No	Sip. No	Sip. No							
CITIZEN	R04	6204	3204	Ø 8.0	36	Ø 11.5						
	R07, D/F/G/L-10	6910	3910	Ø 15.0	64	Ø 21.0	F15/580	120E	TF15	40.003		
	B12, F12	6212	3212	Ø 16.0	64	Ø 21.0						
	D/E/F/L/M-16,E/F/L/M-20	6720	3720	Ø 25.0	77	Ø 35.0						
	L16/20,F16/20,M16,G20,E20	6216	3216	Ø 26.0	67	Ø 36.0						511.001
	F25, L25, E25, E25J	6225	3225	Ø 30.0	78	Ø 42.0						
	L32, M32, E32, G32	6232	3232	Ø 37.0	92	Ø 47.0						
STAR	JNC8	6508	3508	Ø 12.0	51	Ø 20.0						
	SW7/SW10/JNC10,RNC10,SNC10	6910	3910	Ø 15.0	64	Ø 21.0	F15/580	120E	TF15	40.003		
	SE12, S13, VNC12, SJ15	6512	3512	Ø 18.0	64	Ø 25.0						
	SB16	6616	3616	Ø 20.0	67	Ø 26.0						
	RNC16, SE16, SR16, SH16	6516	3516	Ø 20.0	67	Ø 28.0	F20/87	138E	TF20	40.004		
	JNC16, VNC20	6520	3520	Ø 24.0	65.5	Ø 32.0						
	KNC16/20, SR20, VNC20	6720	3720	Ø 25.0	77	Ø 35.0						
	JNC16, ZNC16, VNC20	6216	3216	Ø 26.0	67	Ø 36.0						
	KJR25, SCN25	6725	3725	Ø 30.0	80	Ø 42.0	F30/63	157E	TF30	40.006		
	JNC32/25, VNC32, MR32	6232	3232	Ø 37.0	92	Ø 47.0						
STM38	1242	2242	Ø 48.0	94	Ø 60.0	F48/81	173E	TF48	231.009			
TSUGAMI	T7, BO07, BM07, NP-4W	6707	3707	Ø 10.0	46	Ø 16.0	F10/1178	111E			140.001	
	L10	6710	3710	Ø 14.0	47	Ø 20.0						
	NT/NP11	6910	3910	Ø 15.0	64	Ø 21.0	F15/580	120E	TF15	40.003		
	BO12, NT/NP-12	6616	3616	Ø 20.0	67	Ø 26.0						
	NP17, NP16, NT17	6717	3717	Ø 23.8	62	Ø 28.0				S16-HMS		
	BO18A, S20, BS18	6721	3721	Ø 28.0	77	Ø 35.0				S20-HM		
	BO18B, S20, BS18	6720	3720	Ø 25.0	77	Ø 35.0						
	BS26A, BS25	6726	3726	Ø 33.0	80	Ø 40.0				S25-HM		
	BS26B, BS25	6725	3725	Ø 30.0	80	Ø 42.0	F30/63	157E	TF30	40.006		
	NT/NP-32	6232	3232	Ø 37.0	92	Ø 47.0						
	BH38	6738	3738	Ø 43.0	92	Ø 53.0	F43		TF43	511.024		
	BH38(SUB)	6739	3739	Ø 48.0	100	Ø 54.0	F48			BS38	511.028	

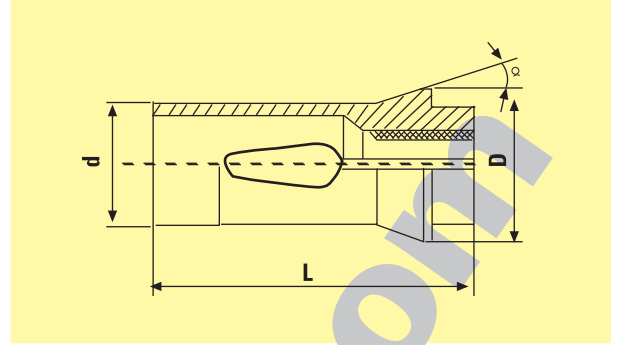

CNC Kayar Otomat Pensleri

Tezgah	Model	Karbür		Çelik		d	L	D	Muadil No			
		Sip. No	Sip. No	Sip. No	Sip. No							
NOMURA	NSP8410, NSP8420	6608	3608	Ø 12.0	58	Ø 18.0						
	NSP1053, NN10K	6610	3610	Ø 16.0	50.5	Ø 22.0						90.015
	NSP1653, NSP1253	6616	3616	Ø 20.0	68	Ø 26.0						
	NN20KF	6216	3216	Ø 26.0	67	Ø 36.0						511.001
	P-23	6623	3623	Ø 29.0	72	Ø 39.0						
	NNCP2553, NN25K	6625	3625	Ø 32.0	84.5	Ø 42.0						
	P-32	6632	3632	Ø 42.0	86	Ø 52.0						
TORNOS	M4, T4, TV	6904	3904	Ø 8.0	42	Ø 12.0	F8/577	101E	TF8			40.001
	M7	6907	3907	Ø 10.0	47.5	Ø 15.5	F10/86	109E	TF10			40.002
	MS7	6108	3108	Ø 13.0	64	Ø 19.0	F13/357	116E	TF13			40.016
	R10, M10	6910	3910	Ø 15.0	64	Ø 21.0	F15/580	120E	TF15			40.003
	R125	6912	3912	Ø 16.0	64	Ø 21.0	F16/1076	1212E	TF16			40.012
	R16, M15	6516	3516	Ø 20.0	67	Ø 28.0	F20/87	138E	TF20			40.004
	RR20, R20, M20	6920	3920	Ø 25.0	77	Ø 35.0	F25/64	145E	TF25			40.005
	M25	6725	3725	Ø 30.0	80	Ø 42.0	F30/63	157E	TF30			40.006
	MR32, TBM32	6932	3932	Ø 37.0	92	Ø 47.0	F37/740	1536E	TF37			40.008
TORNOS-DECO	DECO 7	6907	3907	Ø 10.0	47.5	Ø 15.5	F10/86	109E	TF10			40.002
	DECO 10	6910	3910	Ø 15.0	64	Ø 21.0	F15/580	120E	TF15			40.003
	DECO 13	6912	3912	Ø 16.0	64	Ø 21.0	F16/1076	1212E	TF16			40.012
	DECO 13/16	6816	3816	Ø 20.0	54	Ø 26.0	F20/201	136E	F20-201			225.003
	DECO 20, DELTA 12/20	6920	3920	Ø 25.0	77	Ø 35.0	F25/64	145E	TF25			40.005
	DECO 26, SIGMA 20	6826	3826	Ø 30.0	65	Ø 38.0	F30/101	1446E	O161			90.009
	DECO 32	6932	3932	Ø 37.0	92	Ø 47.0	F37/740	1536E	TF37			40.008
	DELTA 38/5	6738	3738	Ø 43.0	92	Ø 53.0	F43		TF43			511.024
	DELTA 38/5 (SUB)	6739	3739	Ø 48.0	100	Ø 54.0	F48		BS38			511.028
BECHLER	A4, A7	6107	3107	Ø 10.0	46	Ø 16.0						
	A7, A10, AR10	6110	3110	Ø 14.0	46	Ø 18.0	F14/98	117E				140.002
	B12	6112	3112	Ø 18.0	67	Ø 25.0	F18/85	127E				140.003
	B16	6116	3116	Ø 22.0	67	Ø 28.0	F22/88	139E				140.004
	B20, BR20	6120	3120	Ø 26.0	67	Ø 32.0	F26/90	146E				140.005
BECHLER ENC	ENC 74/75	6108	3108	Ø 13.0	64	Ø 19.0	F13/357	116E	TF13			40.016
	ENC 162/164	6816	3816	Ø 20.0	54	Ø 26.0	F20/201	136E	F20-201			225.003
	ENC 163/167	6920	3920	Ø 25.0	77	Ø 35.0	F25/64	145E	TF25			40.005

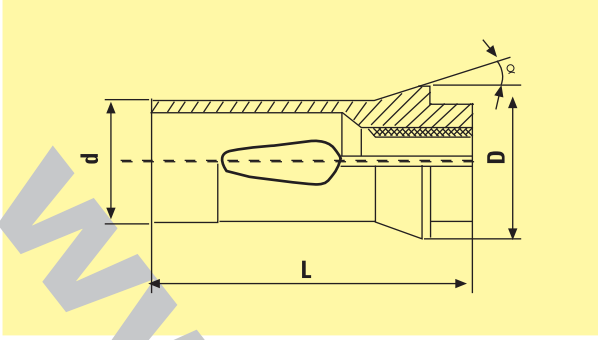

CNC Kayar Otomat Pensleri

Tezgah	Model	Karbür		Çelik		d	L	D	Muadil No			
		Sip. No	Sip. No	Sip. No	Sip. No							
STROHM	M75-M105	6907	3907	Ø 10.0	47.5	Ø 15.5	F10/86	109E	TF10	40.002		
	M105/125	6910	3910	Ø 15.0	64	Ø 21.0	F15/580	120E	TF15	40.003		
	M205/255	6920	3920	Ø 25.0	77	Ø 35.0	F25/64	145E	TF25	40.005		
	M205/255	6725	3725	Ø 30.0	80	Ø 42.0	F30/63	157E	TF30	40.006		
TRAUB	TNL 7	6907	3907	Ø 10.0	47.5	Ø 15.5	F10/86	109E	TF10	40.002		
	TNL 12/7	6910	3910	Ø 15.0	64	Ø 21.0	F15/580	120E	TF15	40.003		
	TNL 12/7	6912	3912	Ø 16.0	64	Ø 21.0	F16/1076	1212E	TF16	40.012		
	TNL 16	6816	3816	Ø 20.0	54	Ø 26.0	F20/201	136E	F20-201	225.003		
	TNL 16	6516	3516	Ø 20.0	67	Ø 28.0	F20/87	138E	TF20	40.004		
	TNL 20	6920	3920	Ø 25.0	77	Ø 35.0	F25/64	145E	TF25	40.005		
WANG TZYY	SL-1693	6616	3616	Ø 20.0	68	Ø 26.0						
	SL-2596	6225	3225	Ø 30.0	78	Ø 42.0						
	SL-3295	6232	3232	Ø 37.0	92	Ø 47.0						
POLYGYM	DIAMOND 12, 12CS	6212	3212	Ø 16.0	64	Ø 21.0						
	DIAMOND 16, 16CS	6616	3616	Ø 20.0	68	Ø 26.0						
	DIAMOND 20, 20B, 20CS, 20CSB	6216	3216	Ø 26.0	67	Ø 36.0					511.001	
	DIAMOND 25, 25B, 25CS, 25CSB	6225	3225	Ø 30.0	78	Ø 42.0						
	DIAMOND 32, 32B, 32CS, 32CSB	6232	3232	Ø 37.0	92	Ø 47.0						
	DIAMOND SY-42	1242	2242	Ø 48.0	94	Ø 60.0	F48/81	173E	TF48	231.009		
JINN FA	JSL-20	6721	3721	Ø 28.0	77	Ø 35.0						
	JSL-26	6726	3726	Ø 33.0	80	Ø 40.0						
	JSL-32	6232	3232	Ø 37.0	92	Ø 47.0						
	JSL-42AB	1342	2342	Ø 54.0	87	Ø 68.0						
HANWHA	HANEX11, SL 12	6912	3912	Ø 16.0	64	Ø 21.0	F16/1076	1212E	TF16	40.012		
	HANEX17, ML 18-G	1215	2215	Ø 22.0	55	Ø 30.0	F22/71	140E		231.002		
	HANEX 20	6920	3920	Ø 25.0	77	Ø 35.0	F25/64	145E	TF25	40.005		
	HANEX 25	6425	3425	Ø 32.0	79	Ø 45.0						
	SL-32	6932	3932	Ø 37.0	92	Ø 47.0	F37/740	1536E	TF37	40.008		
	SL-35	6435	3435	Ø 40.0	92	Ø 49.0						
	SL-35HP-II,SUB	6436	3436	Ø 40.0	92	Ø 50.0						
	SL-38HP-II	6438	3438	Ø 44.0	94	Ø 52.0	F44				511.026	
NEXTURN	SA-12	6912	3912	Ø 16.0	64	Ø 21.0	F16/1076	1212E	TF16	40.012		
	SA-18, SA-20, SA-20e	6920	3920	Ø 25.0	77	Ø 35.0	F25/64	145E	TF25	40.005		
	SA-26, SA-26e	1225	2225	Ø 32.0	75	Ø 45.0	F32/221	161E		231.005		
	SA-32	6932	3932	Ø 37.0	92	Ø 47.0	F37/740	1536E	TF37	40.008		

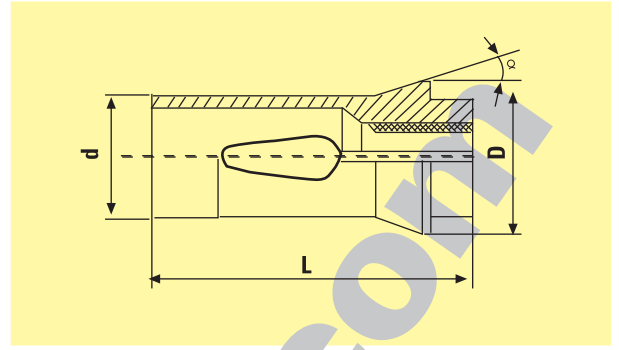

CNC Kayar Otomat Pensleri

Tezgah	Model	Karbür		Çelik		d	L	D	Muadil No		
		Sip. No	Sip. No	Sip. No	Sip. No						
GAUTHIER	GM12	6816	3816	Ø 20.0	54	Ø 26.0	F20/201	136E	F20-201	225.003	
	GM20	6920	3920	Ø 25.0	77	Ø 35.0	F25/64	145E	TF25	40.005	
	GM25	6725	3725	Ø 30.0	80	Ø 42.0	F30/63	157E	TF30	40.006	
GILDEMEISTER	GLD12	6516	3516	Ø 20.0	67	Ø 28.0	F20/87	138E	TF20	40.004	
	GLD16/20,GS20-L	6920	3920	Ø 25.0	77	Ø 35.0	F25/64	145E	TF25	40.005	
	GLD25L,GS25-L	1225	2225	Ø 32.0	75	Ø 45.0	F32/221	161E		231.005	
PETERMANN	P4,P7	6004	3004	Ø 8.0	41	Ø 12.0	F8/1079			90.002	
	P7	6907	3907	Ø 10.0	47.5	Ø 15.5	F10/86	109E	TF10	40.002	
	P7R	6010	3010	Ø 15.0	47	Ø 22.0	F15/358	121E		90.004	
	P10, 10HSR	6011	3011	Ø 16.0	55	Ø 22.0	F16/104	123E		90.005	
	P16	6016	3016	Ø 22.0	66	Ø 32.0	F22/727			90.007	
MANURHIN	Swing 13, Traminer 13	6112	3112	Ø 18.0	67	Ø 25.0	F18/85	127E		140.003	
	Twin 13, Decotum 16	6516	3516	Ø 20.0	67	Ø 28.0	F20/87	138E	TF20	40.004	
	Traminer 16	6816	3816	Ø 20.0	54	Ø 26.0	F20/201	136E	F20-201	225.003	
	KMX, Swing, Traminer, Twin 20	6920	3920	Ø 25.0	77	Ø 35.0	F25/64	145E	TF25	40.005	
	KMX26, Twin 20, Swing20	1225	2225	Ø 32.0	75	Ø 45.0	F32/221	161E		231.005	
	Mirabel PM 32	1232	2232	Ø 38.1	108	Ø 49.0	F38/72	164E		285.002	
MAIER	ML7	6907	3907	Ø 10.0	47.5	Ø 15.5	F10/86	109E	TF10	40.002	
	ML12G, ML12S, ML 125K II	6910	3910	Ø 15.0	64	Ø 21.0	F15/580	120E	TF15	40.003	
	ML18S, ML18H, ML 20D	6920	3920	Ø 25.0	77	Ø 35.0	F25/64	145E	TF25	40.005	
	ML26S, ML26H	6725	3725	Ø 30.0	80	Ø 42.0	F30/63	157E		40.006	
	ML26D	1225	2225	Ø 32.0	75	Ø 45.0	F32/221	161E		231.005	
	ML36	1236	2236	Ø 42.0	94	Ø 55.0	F42/99	171E		231.007	
HARDINGE	S20, ST220	6920	3920	Ø 25.0	77	Ø 35.0	F25/64	145E	TF25	40.005	
	ST225	6725	3725	Ø 30.0	80	Ø 42.0	F30/63	157E	TF30	40.006	
DMG	GMC 20	6320	3320	Ø 25.0	77	Ø 35.0					

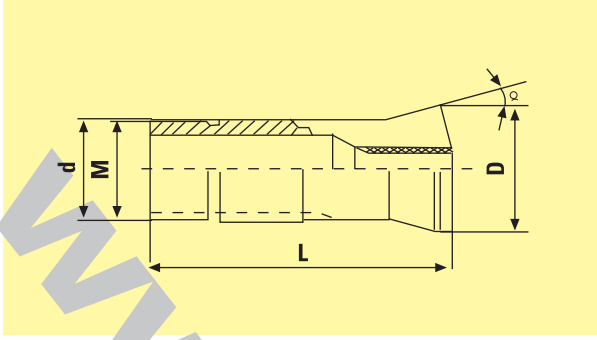

CNC Kayar Otomat Karbür Yataklama Pensleri

Tezgah	Model	Sipariş No	d	L	D	Diş M	Muadil No		
CITIZEN	R04	5204	Ø 9.0	38.5	Ø 12.5	M8X0.75		263.001	
	R07	5907	Ø 11.0	52	Ø 14.5	M10X0.75	3134E	3.001	TD-7
	D10, E10, F10, L10	5910	Ø 16.0	59	Ø 20.5	M14X1.0	3260E	8.001	TD-10
	B12, F12, C12, A12	5212	Ø 18.0	60	Ø 22.0	M18X1.0	3319E	174.001	SD125R
	B20, M20, L20	5920	Ø 28.0	82	Ø 34.0	M25X1.0	3602E	22.001	TD25S
	L16/20, F16/F20, E20, WF6, 206M	5216	Ø 30.0	59	Ø 35.0	M30X1.0		510.001	
	F25, L25, E25, E25J	5725	Ø 34.0	87.5	Ø 41.0	M34X1.0	3733E	451.001	CD25
	L32, M32, G32, E32	5232	Ø 42.0	82	Ø 48.0	M40X1.0		28.01	TD32
STAR	TD-7	5907	Ø 11.0	52	Ø 14.5	M10X0.75	3134E	3.001	TD-7
	JNC-10, RNC-10, SNC-10	5910	Ø 16.0	59	Ø 20.5	M14X1.0	3260E	8.001	TD10
	SE12, VNC12, SJ15, SNC15	5512	Ø 21.0	58	Ø 24.0	M18X1.0	3438E	450.001	SNC15
	SB16, SR16	5616	Ø 22.0	70.5	Ø 26.0	M20X1.0		487.001	P1653D
	RNC16, SE16, SA16, VNC16, KNC16	5516	Ø 22.0	68	Ø 29.0	M22X1.0			
	SA-16, SR-16	5916	Ø 22.0	68	Ø 29.0	M22X1.0	3455E	39.001	TD20R
	SR20, KNC16, VNC20	5920	Ø 28	82	Ø 34.0	M25X1.0	3602E	22.001	TD25S
	JNC16, L16/20, ZNC16, VNC20	5216	Ø 30.0	59	Ø 35.0	M30X1.0		510.001	
	SCN-25, KJR-25	5725	Ø 34.0	87.5	Ø 41.0	M34X1.0	3733E	451.001	CD25
	JNC32/25, VNC32/25, MR32, SR32	5532	Ø 42.0	82	Ø 49.0	M40X1.0	3827E	28.001	TD32S
	STM-38	5538	Ø 48.0	82	Ø 59.0	M46X1.0		464.001	
TSUGAMI	NP-4W	5907	Ø 11.0	52	Ø 14.5	M10X0.75	3134E	3.001	TD-7
	T7, B007, BM07	5707	Ø 12.0	52	Ø 15.8	M12X1.0	3149E	261.001	
	L10	5710	Ø 15.0	54	Ø 19.0	M14X1.0			
	NT-11, NP-11	5212	Ø 18.0	60	Ø 22.0	M18X1.0	3319E	174.001	SD125R
	B012	5616	Ø 22.0	70.5	Ø 26.0	M20X1.0		487.001	P1653D
	NP-17, NP-16, NT-17	5717	Ø 23	72	Ø 28.0	M22X1.0		483.001	TSG20R
	NP-20, BS20, B018, BS18	5720	Ø 30.0	70	Ø 36.0	M28X1.0		486.001	NN20KD
	B020-CV	5721	Ø 26.0	77	Ø 29.0	M25X1.0			TD26
	BA-26	5726	Ø 33.0	70	Ø 38.0	M30X1.0			
	BA-26L	5724	Ø 32.0	70	Ø 38.0	M30X1.0			
	S-25, BS-26	5725	Ø 34.0	87.5	Ø 41.0	M34X1.0	3733E	451.001	CD25
	NP 32	5532	Ø 42.0	82	Ø 49.0	M40X1.0	3827E	28.001	TD32S
	BH38	5738	Ø 48.0	81	Ø 54.0	M46X1.0			

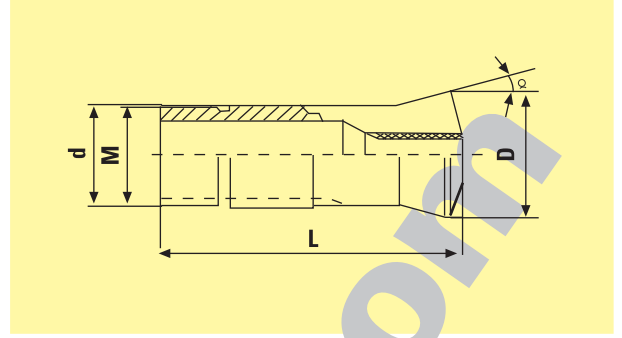

CNC Kayar Otomat Karbür Yataklama Pensleri

Tezgah	Model	Sipariş No	d	L	D	Diş M	Muadil No		
NOMURA	NS-P8410, NS-P8420	5608	Ø 14.0	60.5	Ø 20.0	M14X1.0		480.001	P853D
	NS-P1053, NN-10K	5610	Ø 16.0	63	Ø 20.0	M14X1.0		481.001	P1053D
	NS-P1653, NS-P1253	5616	Ø 22.0	70.5	Ø 26.0	M20X1.0		487.001	P1653D
	NN-P20, NN-20KF	5620	Ø 30.0	67.5	Ø 35.0	M30X1.0			
	NNC-P2553, NN-25K	5625	Ø 36.0	89	Ø 44.0	M36X1.0			
	P-32	5632	Ø 44.0	90	Ø 50.0	M40X1.0			
TORNOS	M4, T4, TV	5904	Ø 9.0	44	Ø 12.0	M8X0.75	3077E	1.001	PD-4
	M7	5907	Ø 11.0	52	Ø 14.5	M10X0.75	3134E	3.001	TD-7
	M7, MS7	5908	Ø 13.0	68	Ø 17.0	M13X1.0		45.001	
	R10, M10, R125, MS7	5910	Ø 16.0	59	Ø 20.5	M14X1.0	3260E	8.001	TD10
	R10, M10, R125	5212	Ø 18.0	60	Ø 22.0	M18X1.0	3319E	174.001	SD125R
	M15, R16, RR20	5915	Ø 22.0	68	Ø 29.0	M19X1.0	3454E	13.001	TD20
	M15, R16, RR20	5916	Ø 22.0	68	Ø 29.0	M22X1.0	3455E	39.001	TD20R
	RR20	5920	Ø 28.0	82	Ø 34.0	M25X1.0	3602E	22.001	TD25S
	M20, M25	5925	Ø 32.0	70.5	Ø 40.0	M32X1.0	3708E	282.001	TSD20
MR32	5932	Ø 44.0	87.5	Ø 53.0	M40X1.0	3835E	27.001		
TORNOS-DECO	DECO 2000-7	5907	Ø 11.0	52	Ø 14.5	M10X0.75	3134E	3.001	TD-7
	DECO 2000-10	5910	Ø 16.0	59	Ø 20.5	M14X1.0	3260E	8.001	TD10
	DECO 2000-13/16	5816	Ø 24.0	61	Ø 29.5	M24X1.0	3507E	61.002	O201
	DELTA 12/20	5721	Ø 26.0	77	Ø 29.0	M25X1.0		99.001	TD26
	DECO 2000-20	5820	Ø 28.0	82	Ø 38.0	M25X1.0	3610E	18.001	TD25/167
	DECO 2000-26	5725	Ø 34.0	87.5	Ø 41.0	M34X1.0	3733E	451.001	CD25
	DECO 2000-32	5532	Ø 42.0	82	Ø 49.0	M40X1.0	3827E	28.001	TD32S
	DELTA 38/5	5738	Ø 48.0	81	Ø 54.0	M46X1.0		496.001	
BECHLER	A4, A7	5904	Ø 9.0	44	Ø 12.0	M8X0.75	3077E	1.001	PD-4
	A7, A10	5107	Ø 12.0	52	Ø 15.0	M12X1.0	3149E	261.001	
	A7, A10, AR10	5915	Ø 22.0	68	Ø 29.0	M19X1.0	3454E	13.001	TD20
	B12, B16, B20	5820	Ø 28.0	82	Ø 38.0	M25X1.0	3610E	18.001	TD25/167
BECHLER ENC	74/75	5910	Ø 16.0	59	Ø 20.5	M14X1.0	3260E	8.001	TD10
	162/164	5816	Ø 24.0	61	Ø 29.5	M24X1.0	3507E	61.002	O201
	163/167	5820	Ø 28.0	82	Ø 38.0	M25X1.0	3610E	18.001	TD25/167

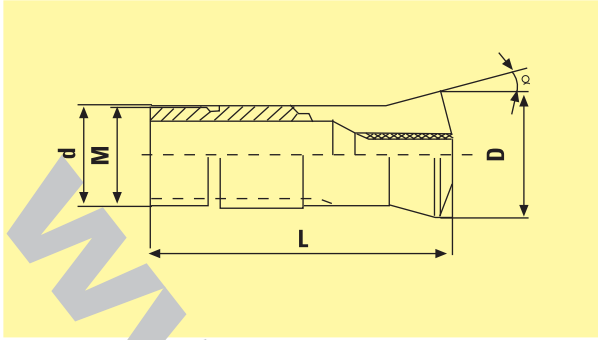

CNC Kayar Otomat Karbür Yataklama Pensleri

Tezgah	Model	Sipariş No	d	L	D	Diş M	Muadil No		
STROHM	M75/105	5907	Ø 11.0	52	Ø 14.5	M10X0.75	3134E	3.001	TD-7
	M105/125	5312	Ø 18.0	60	Ø 22.0	M16X1.0	3320E	166.001	SD125R16
	M205/255	5915	Ø 22.0	68	Ø 29.0	M19X1.0	3454E	13.001	TD20
TRAUB	TNL 12/7	5312	Ø 18.0	60	Ø 22.0	M16X1.0	3320E	166.001	SD125R16
	TNL 16	5916	Ø 22.0	68	Ø 29.0	M22X1.0	3455E	39.001	TD20R
	TNL 17	5920	Ø 28.0	82	Ø 34.0	M25X1.0	3602E	22.001	TD25S
	TNL 20	5820	Ø 28.0	82	Ø 38.0	M25X1.0	3610E	18.001	TD25/167
	TNL 26	5725	Ø 34.0	87.5	Ø 41.0	M34X1.0	3733E	451.001	CD25
WANG TZY	SL-1693	5616	Ø 22.0	70.5	Ø 26.0	M20X1.0		487.001	P1653D
	SL-2596	5725	Ø 34.0	87.5	Ø 41.0	M34X1.0	3733E	451.001	CD25
	SL-3295	5232	Ø 42.0	82	Ø 48.0	M40X1.0		28.01	TD32
POLYGYM	DIAMOND 12,12CS	5212	Ø 18.0	60	Ø 22.0	M18X1.0	3319E	174.001	SD125R
	DIAMOND 16,16CS	5616	Ø 22.0	70.5	Ø 26.0	M20X1.0		487.001	P1653D
	DIAMOND 20, 20B, 20CS, 20CSB	5216	Ø 30.0	59	Ø 35.0	M30X1.0		510.001	
	DIAMOND 25, 25B, 25CS, 25CSB	5725	Ø 34.0	87.5	Ø 41.0	M34X1.0	3733E	451.001	CD25
	DIAMOND 32, 32B, 32CS, 32CSB	5232	Ø 42.0	82	Ø 48.0	M40X1.0		28.01	TD32
	DIAMOND SY-42	5542	Ø 50.0	82	Ø 56.5	M49X1.0			
JINN FA	JSL-20	5720	Ø 30.0	70	Ø 36.0	M28X1.0		486.001	NN20KD
	JSL-26	5725	Ø 34.0	87.5	Ø 41.0	M34X1.0	3733E	451.001	CD25
	JSL-32	5532	Ø 42.0	82	Ø 49.0	M40X1.0	3827E	28.001	TD32S
	JSL-42AB	5742	Ø 52.0	95	Ø 59.0	M50X1.0			
HANWHA	HANEX11, SL12	5212	Ø 18.0	60	Ø 22.0	M18X1.0	3319E	174.001	SD125R
	HANEX17, ML18-G	5916	Ø 22.0	68	Ø 29.0	M22X1.0	3455E	39.001	TD20R
	HANEX20	5920	Ø 28.0	82	Ø 34.0	M25X1.0	3602E	22.001	TD25S
	HANEX25	5725	Ø 34.0	87.5	Ø 41.0	M34X1.0	3733E	451.001	CD25
	SL-32	5532	Ø 42.0	82	Ø 49.0	M40X1.0	3827E	28.001	TD32S
	SL-35, SL-38	5435	Ø 45.0	82	Ø 52.0	M42X1.0			
	SL-38HP II	5438	Ø 46.0	82	Ø 53.0	M45X1.0			
NEXTURN	SA-12	5312	Ø 18.0	60	Ø 22.0	M16X1.0	3320E	166.001	SD125R16
	SA-12	5212	Ø 18.0	60	Ø 22.0	M18X1.0	3319E	174.001	SD125R
	SA-18, SA-20, SA-20e	5920	Ø 28.0	82	Ø 34.0	M25X1.0	3602E	22.001	TD25S
	SA-26, SA-26e	5725	Ø 34.0	87.5	Ø 41.0	M34X1.0	3733E	451.001	CD25
	SA-32	5532	Ø 42.0	82	Ø 49	M40X1.0	3827E	28.001	TD32S

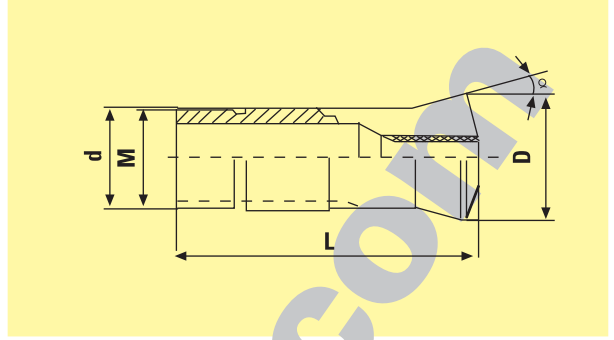

CNC Kayar Otomat Karbür Yataklama Pensleri

Tezgah	Model	Sipariş No	d	L	D	Diş M	Muadil No		
GAUTHIER	1hR	5907	Ø 11.0	52	Ø 14.5	M10X0.75	3134E	3.001	TD-7
	GM12	5910	Ø 16.0	59	Ø 20.5	M14X1.0	3260E	8.001	TD10
	GM20	5915	Ø 22.0	68	Ø 29.0	M19X1.0	3454E	13.001	TD20
GILDEMEISTER	GLD 12	5312	Ø 18.0	60	Ø 22.0	M16X1.0	3320E	166.001	SD125R16
	GLD 16/20, GS20-L	5820	Ø 28.0	82	Ø 38.0	M25X1.0	3610E	18.001	TD25/167
	GLD 25L, GS25-L	5725	Ø 34.0	87.5	Ø 41.0	M34X1.0	3733E	451.001	CD25
PETERMANN	P4, P7	5904	Ø 9.0	44	Ø 12.0	M8X0.75	3077E	1.001	PD-4
	P7R,10,10HS	5910	Ø 16.0	59	Ø 20.5	M14X1.0	3260E	8.001	TD10
	P16	5816	Ø 24.0	61	Ø 29.5	M24X1.0	3507E	61.002	O201
MANURHIN	Swing 13, Traminer 13	5312	Ø 18.0	60	Ø 22.0	M16X1.0	3320E	166.001	SD125R16
	Twin 13, Decotum 16	5916	Ø 22.0	68	Ø 29.0	M22X1.0	3455E	39.001	TD20R
	Traminer 16	5915	Ø 22.0	68	Ø 29.0	M19X1.0	3454E	13.001	TD20
	KMX, Swing, Traminer, Twin 20	5820	Ø 28.0	82	Ø 38.0	M25X1.0	3610E	18.001	TD25/167
	KMX 26	5725	Ø 34.0	87.5	Ø 41.0	M34X1.0	3733E	451.001	CD25
	Mirabel PM 32	5532	Ø 42.0	82	Ø 49.0	M40X1.0	3827E	28.001	TD32S
MAIER	ML7	5907	Ø 11.0	52	Ø 14.5	M10X0.75	3134E	3.001	TD-7
	ML12G, ML12S, ML125K II	5312	Ø 18.0	60	Ø 22.0	M16X1.0	3320E	166.001	SD125R16
	ML18S, ML18H, ML20D	5916	Ø 22.0	68	Ø 29.0	M22X1.0	3455E	39.001	TD20R
	ML20	5920	Ø 28.0	82	Ø 34.0	M25X1.0	3602E	22.001	TD25S
	ML26S, ML26H, ML26D	5725	Ø 34.0	87.5	Ø 41.0	M34X1.0	3733E	451.001	CD25
	ML32	5532	Ø 42.0	82	Ø 49.0	M40X1.0	3827E	28.001	TD32S
HARDINGE	S20, ST220	5720	Ø 30.0	70	Ø 36.0	M28X1.0		486.001	NN20KD
	ST220	5920	Ø 28.0	82	Ø 34.0	M25X1.0	3602E	22.001	TD25S
	ST25, ST225	5725	Ø 34.0	87.5	Ø 41.0	M34X1.0	3733E	451.001	CD25
DMG	GMC 20	5820	Ø 28.0	82	Ø 38.0	M25X1.0	3610E	18.001	TD25/167

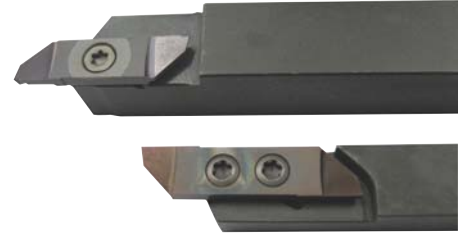
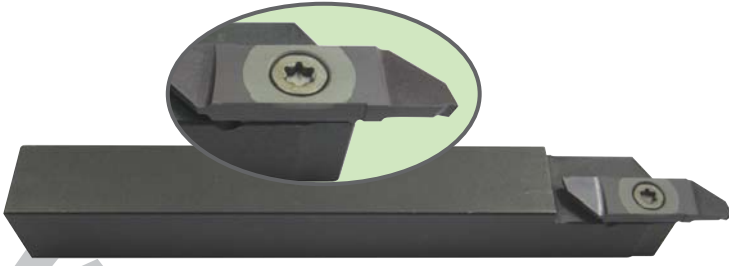

Program 040: Kesme Ø 12 mm

Makina Kapasitesi: 7-12 mm

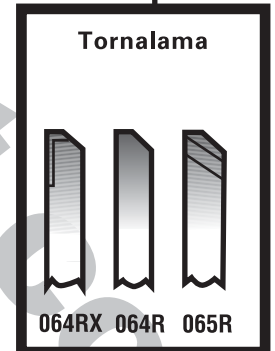
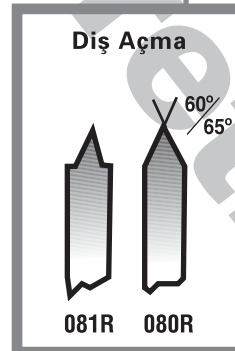
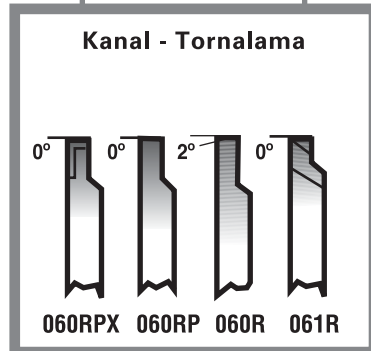
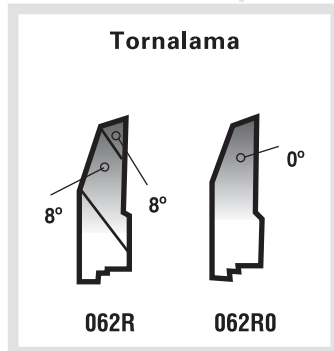
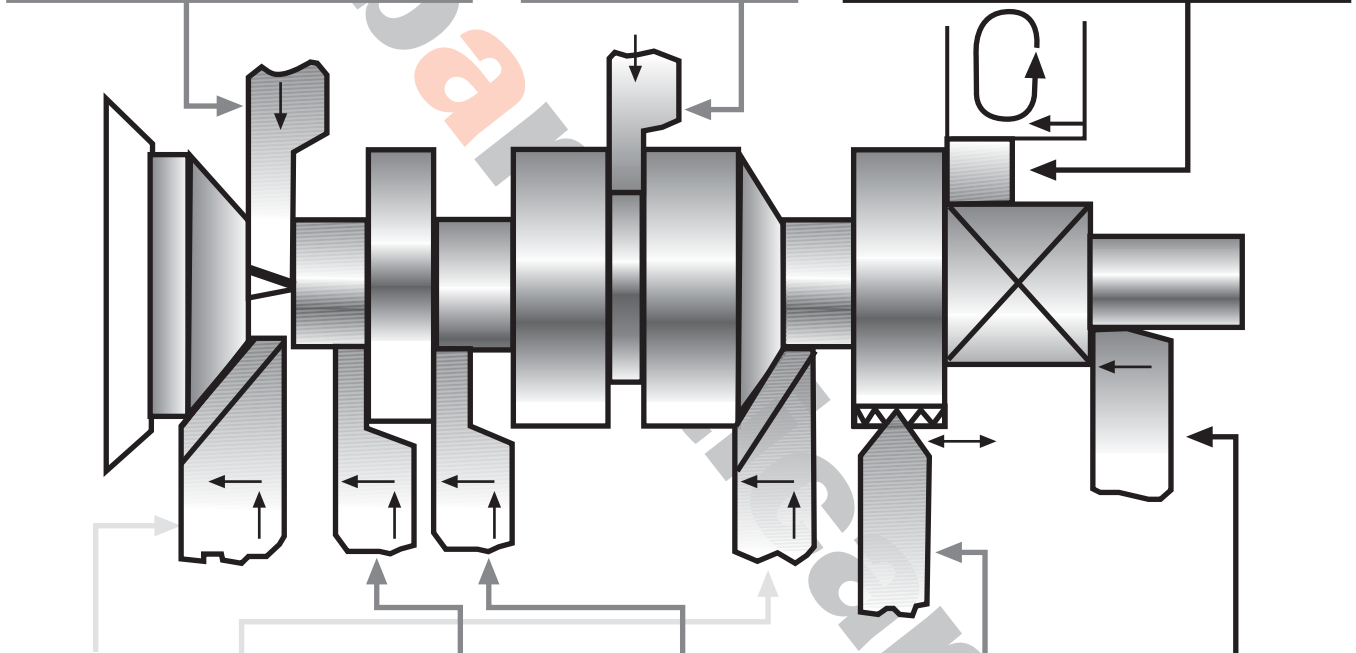
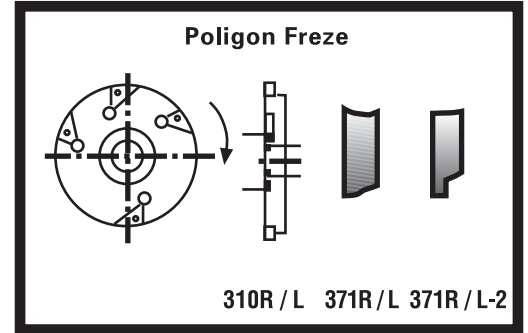
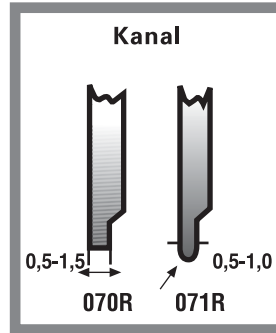
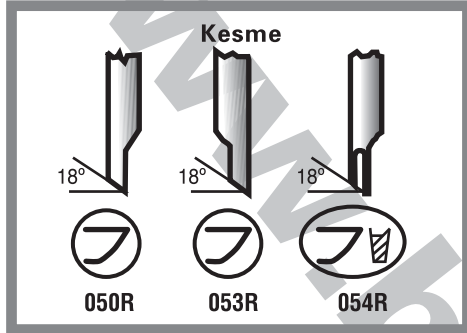

Kaliteler

- TIN Otomat çeliği, pirinç
- BI20 Paslanmaz çelik
- BI40 Yüksek alaşımlı çelik

Katerler (Sağ ve Sol)

7 x 7	12 x 12
8 x 8	16 x 16
10 x 10	20 x 20

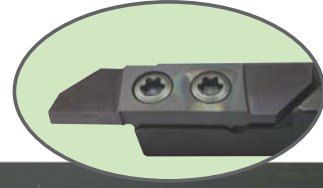
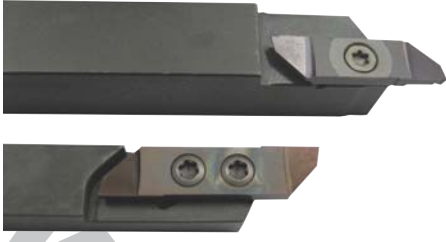

Program 140: Kesme Ø 20 mm

Makina Kapasitesi: 7-20 mm

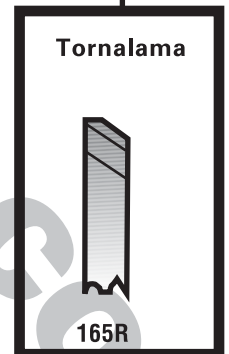
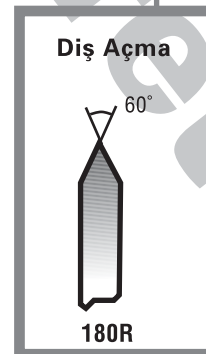
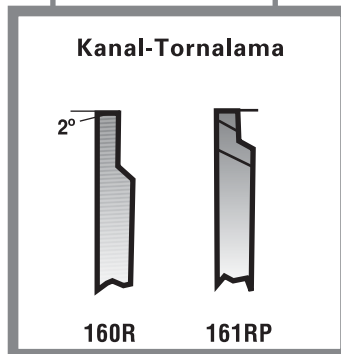
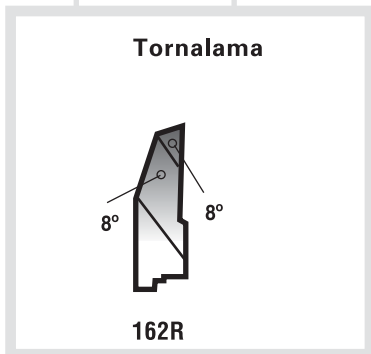
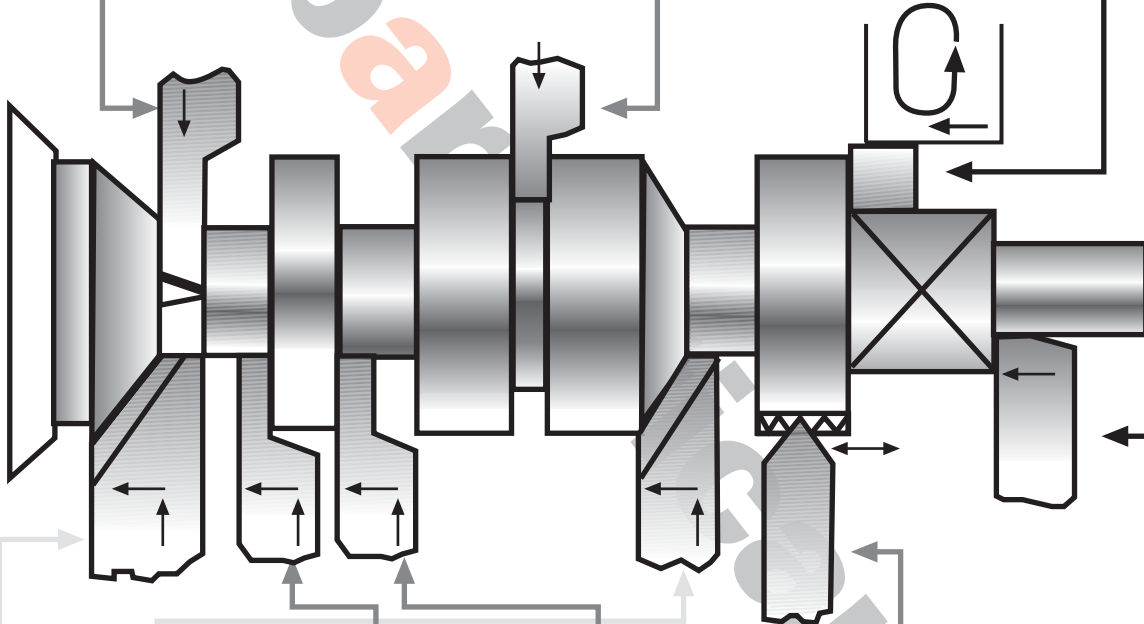
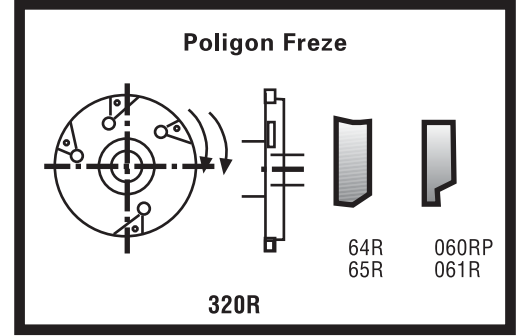
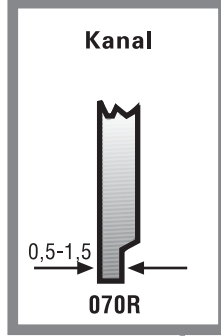
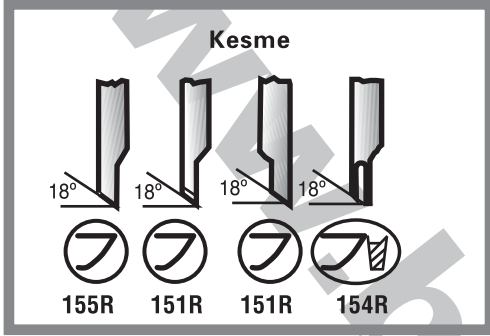

Kaliteler

- TIN Otomat çeliği, pirinç
- BI20 Paslanmaz çelik
- BI40 Yüksek alaşımlı çelik

Katerler (Sağ ve Sol)

- | | |
|---------|---------|
| 12 x 12 | 16 x 16 |
| 10 x 10 | 20 x 20 |

KATERLER SAĞ / SOL

Sipariş Kodu	C	L
007L	7 x 7	140
008L	8 x 8	140
008R	8 x 8	124
010L/R	10 x 10	124
012L/R	12 x 12	124
012R3 90	12 x 12	90
016L/R	16 x 16	100
020R	20 x 20	100
001 - 1	Torx 8	
001 - 2	M2.5 x 7.5	

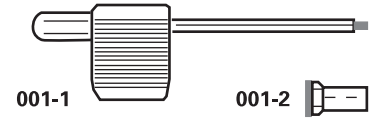
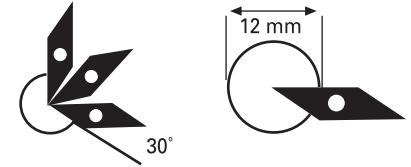
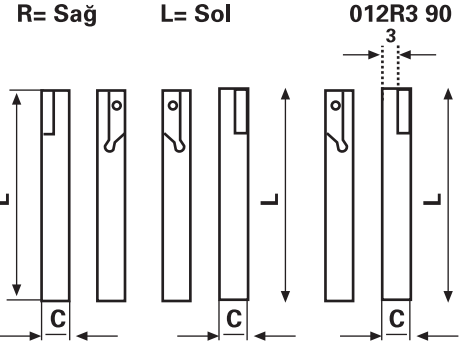

PROFİL UÇ SAĞ / SOL (KAPLAMASIZ)

Sipariş Kodu	e
040R/L	1.4
040R/L	1.7
040R/L	2.0
040R/L	2.2
040R/L	3.5

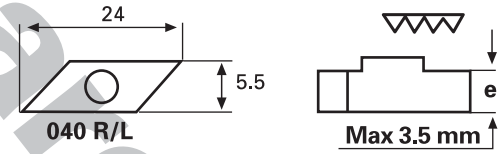

KESME UCU 18° SAĞ / SOL (DÜZ FORM)

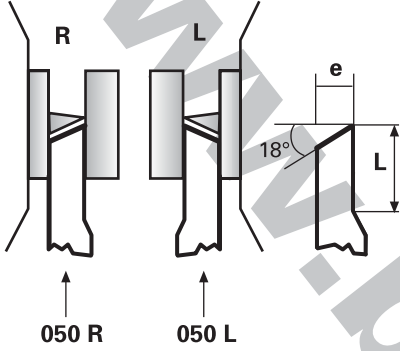

Sipariş Kodu	e	L	Kalite
050R/L	1.0	4.0	BI20 TIN
050R/L	1.2	5.0	
050R/L	1.5	6.5	
050R/L	1.8	6.5	
050R/L	1.0	4.0	BI40
050R/L	1.5	6.5	
050R/L	2.0	6.5	

KESME UCU 8° SAĞ (KEPÇELİ FORM)

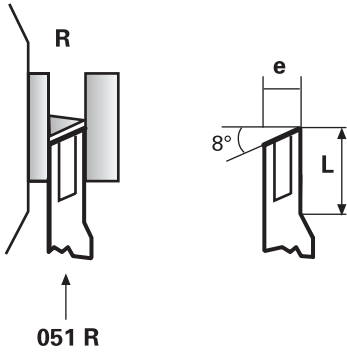

Sipariş Kodu	e	L	Kalite
051R	1.2	5.0	BI20
051R	1.5	6.5	
051R	2.0	6.5	BI40

KESME UCU 18° SAĞ (TALAŞ KIRMALI FORM)

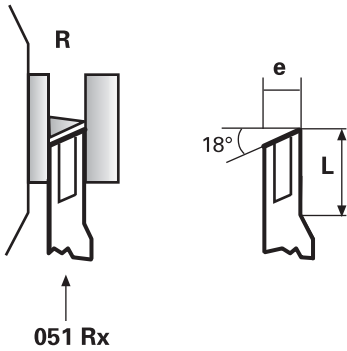

Sipariş Kodu	e	L	Kalite
051Rx	1.5	6.5	BI40
051Rx	2.0	6.5	

KESME UCU 18° SAĞ / SOL (DÜZ FORM)

Sipariş Kodu	e	L	Kalite
053L	1.0	4.0	B120
053L	1.2	5.0	
053L	1.5	6.5	
053R	1.0	4.0	B120
053R	1.2	5.0	
053R	1.5	6.5	
053R	1.8	6.5	
053R	1.2	5.0	B140
053R	1.5	6.5	

Sağ Kesme Ucu
(Sol Açılı)

Sol Kesme Ucu
(Sağ Açılı)

Sol Kesme Ucu
(Sağ Açılı)

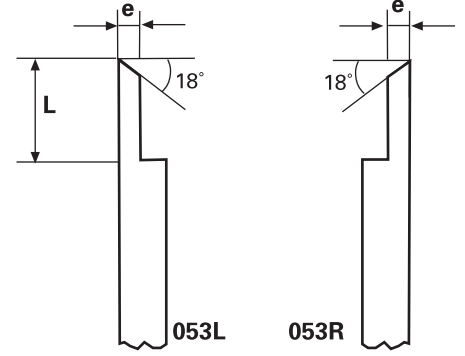

KESME UCU 18° SAĞ / SOL (KEPÇELİ FORM)

Sipariş Kodu	e	L	Kalite
054R/L	1.2	5.0	B120
	1.5	6.5	B140
	2.0	6.5	

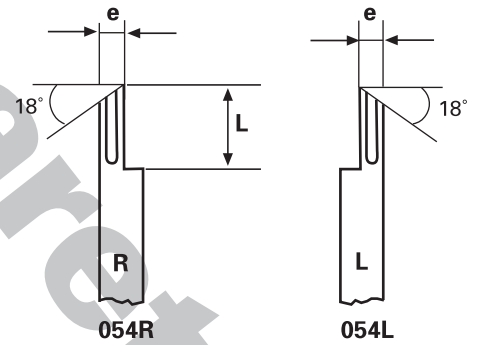

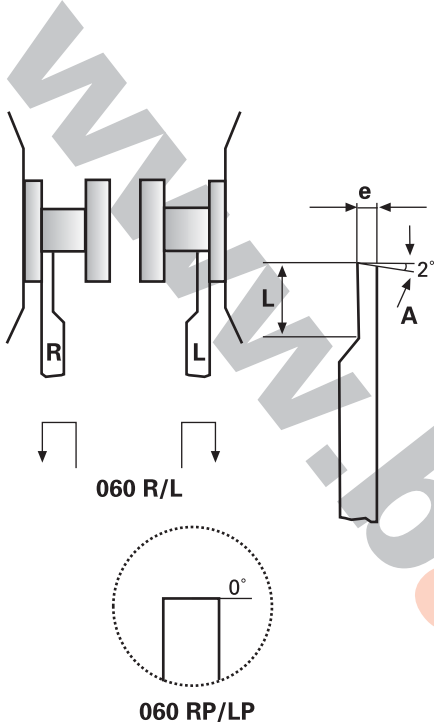

TORNALAMA UCU SAĞ / SOL (DÜZ FORM)

Sipariş Kodu	e	L	Kalite
060 R/L A=2°	1.2	3.0	BI20
	1.5	3.0	
	1.8	4.5	
	2.0	4.5	
060 L A=2°	1.2	3.0	TIN
	1.5	3.0	
	2.0	4.5	
060 RP/LP A=0°	1.0	3.0	BI20
	1.2	3.0	
	1.5	3.0	
	1.8	4.5	
	2.0	4.5	

**TORNALAMA UCU SAĞ / SOL
(TALAŞ KIRMALI FORM)**

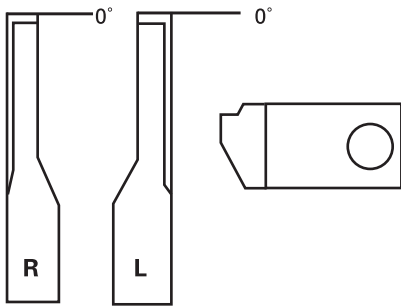

Sipariş Kodu	e	L	Kalite
060RPX 060LPX	1.2	3.0	BI30
	1.5	3.0	
	1.8	4.5	

040 LINE

Kanal ve Tornalama Uçları
R (Sağ) / L (Sol)

KANAL ve TORNALAMA UCU SAĞ / SOL (PARİSLİ FORM)

Sipariş Kodu	e	L	Kalite
061R/L	1.2	3.0	BI20 BI40 TIN
	1.5	3.0	
	2.0	4.5	
	2.5	4.5	

Sipariş Kodu	e	L	Kalite
061R1.5 r0.1	1.5	3.0	BI20 BI40 TIN
061R1.5 r0.2	1.5	3.0	
061R2.0 r0.1	2.0	4.5	
061R2.0 r0.2	2.0	4.5	

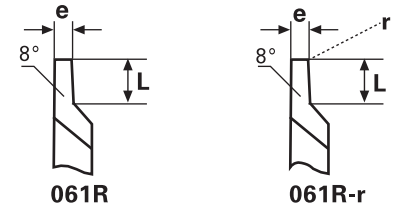
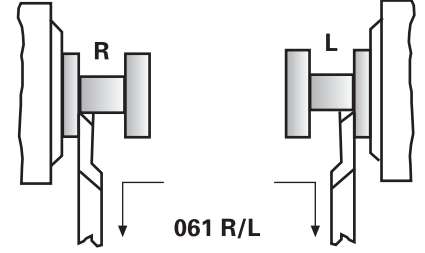

KANAL ve TORNALAMA UCU SAĞ / SOL (KABA İŞLEM ve DÜZELTME)

Sipariş Kodu	e	L	Kalite
062R/L	1.5	4.5	BI20 BI40

Parisli Form

Sipariş Kodu	e	L	Kalite
062R1.6	0.5	4.5	BI40

Parisli Form

Sipariş Kodu	e	L	Kalite
062RO	1.5	4.5	BI20
062LO	1.5	4.5	

Düz Form

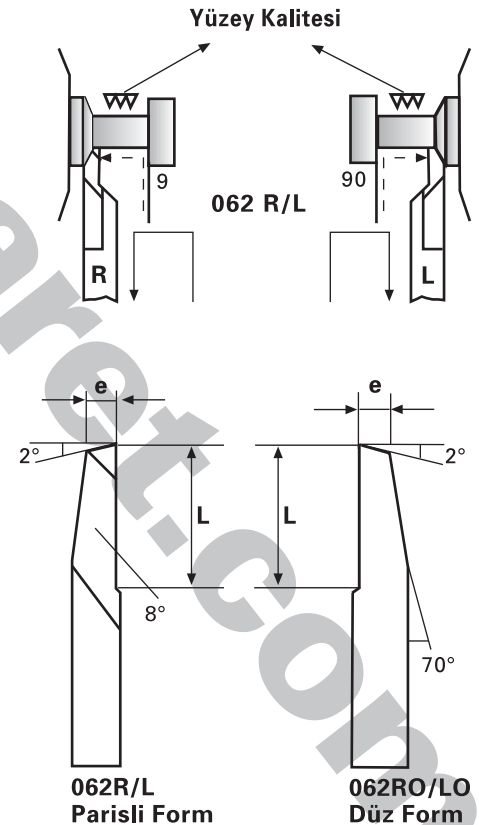

TORNALAMA UCU SAĞ / SOL (DÜZ FORM)

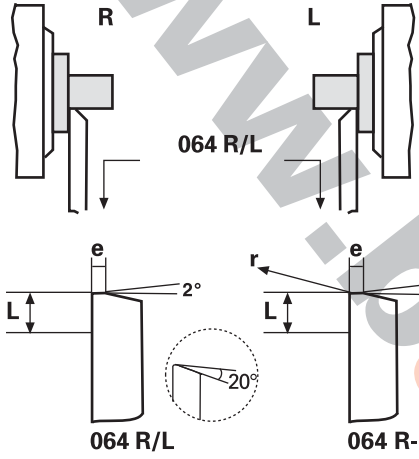

Sipariş Kodu	e	L	Kalite
064R/L	1.5	5.0	BI20 BI40 TIN

Sipariş Kodu r= Radyus	e	L	Kalite
064R r0.1	1.5	5.0	BI20 BI40
064R r0.2	1.5	5.0	

TORNALAMA UCU SAĞ / SOL (TALAŞ KIRMALI FORM)

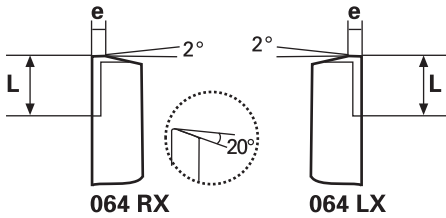

Sipariş Kodu	e	L	Kalite
064RX	1.5	5.0	BI30
064LX	1.5	5.0	

TORNALAMA SAĞ / SOL (PARİSLİ FORM)

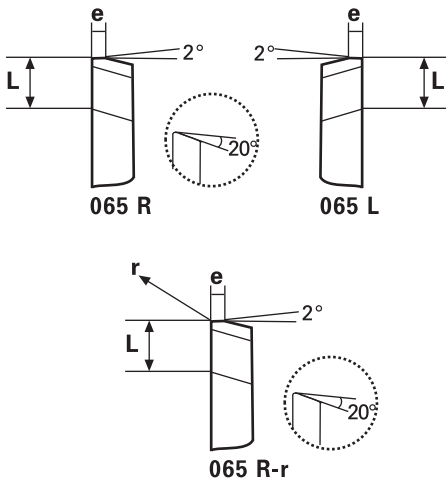

Sipariş Kodu	e	L	Kalite
065R/L	1.5	5.0	BI20 BI40 TIN

Sipariş Kodu r= Radyus	e	L	Kalite
065R r0.1	1.5	5.0	BI20 BI40
065R r0.2	1.5	5.0	

KANAL AÇMA UCU SAĞ / SOL (DÜZ FORM)

Sipariş Kodu	e	L	Kalite
070R/L	0.35	1.0	BI20
	0.4	1.0	
	0.5	1.5	
	0.6	1.5	
	0.7	2.5	
	0.8	1.5	
	0.9	2.0	
	1.0	2.5	
	1.1	2.5	
	1.2	2.5	
	1.3	2.5	
	1.4	2.5	
	1.5	2.5	

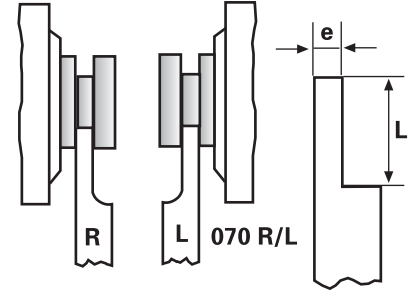

RADYUSLU KANAL AÇMA UCU SAĞ / SOL (DÜZ FORM)

Sipariş Kodu r= Radius	e	L	Kalite
071R/L r0.25	0.5	2.0	BI40
071R/L r0.4	0.8	2.0	
071R/L r0.5	1.0	3.0	
071R/L r0.6	1.2	3.0	
071R/L r0.75	1.5	3.0	
071R/L r1.0	2.0	3.0	

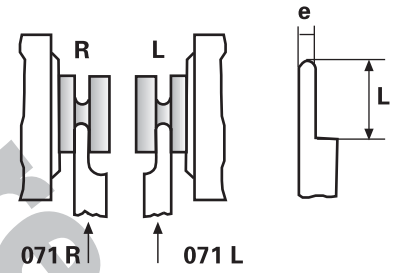

PROFİL DİŞ AÇMA UCU SAĞ / SOL

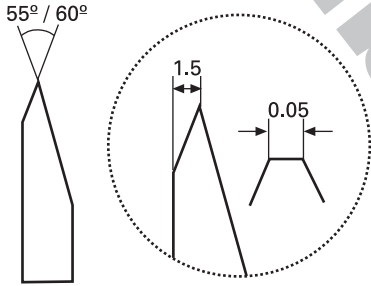
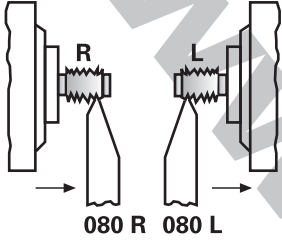

Sipariş Kodu		Kalite
080R	ISO 60°	BI20
080L		
080R	W 55°	BI20
080L		

METRİK DİŞ AÇMA UCU SAĞ

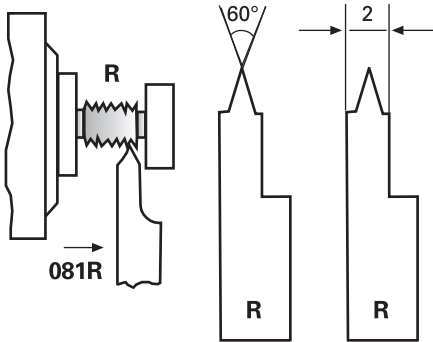

Sipariş Kodu	e	Hatve	Kalite
081 R	0.20	-	BI40
	0.25	M1/1.2	
	0.3	M1.4	
	0.35	M1.6	
	0.4	M2	
	0.45	M2.5	
	0.5	M3	
	0.7	M4	
	0.75	-	
	0.8	M5	
	1.0	M6	
	1.25	M8	
1.50	M10		

KATERLER SAĞ / SOL

Sipariş Kodu	C	L
110R/L	10 x 10	120
112R/L	12 x 12	120
114R/L	14 x 14	120
116R/L	16 x 16	100
120R/L	20 x 20	100
100 - 1	Torx 15	
100 - 2	M 3.5	

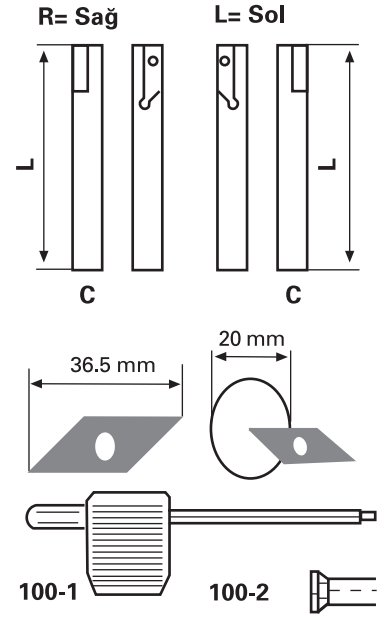

KATERLER SAĞ / SOL

Sipariş Kodu	C	L
110R4	10 x 10	120
112R/L4	12 x 12	120
116R/L4	16 x 16	120
120R6	20 x 20	120
100 - 1	Torx 15	
100 - 2c	M 3.5 x 7	

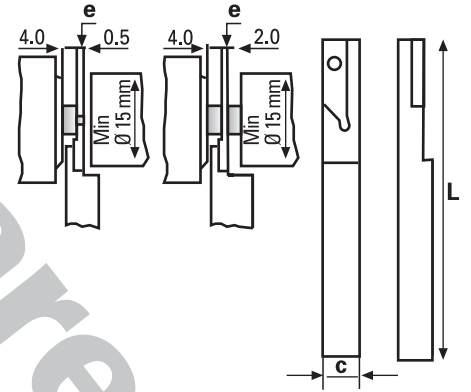

PROFİL UÇ SAĞ / SOL KAPLAMASIZ (TAŞLANMIŞ)

Sipariş Kodu	e	Kalite
140R/L	4.0	K10

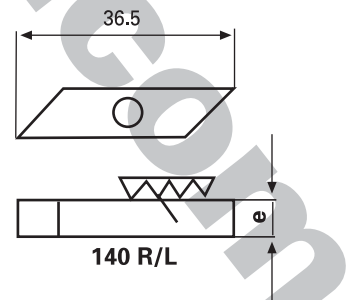

KESME UÇ 8° SAĞ / SOL (KEPÇELİ FORM)

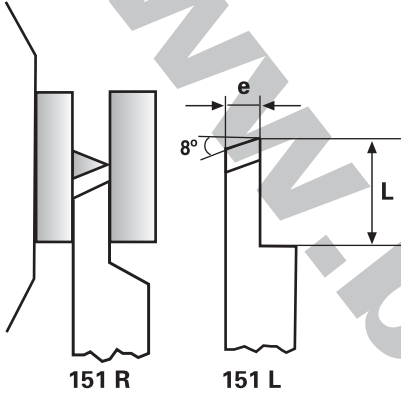

Sipariş Kodu	e	L	Kalite
151R/L	1.8	8.0	BI20
151R/L	2.0	10.0	
151R/L	2.5	10.5	

KESME UÇ SOL 18° (DÜZ ve KEPÇELİ FORM)

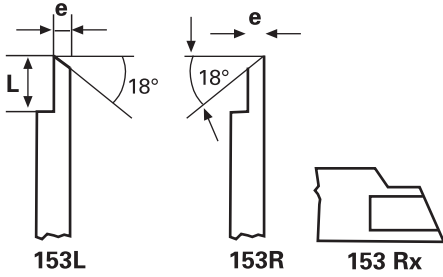

Sipariş Kodu	e	L	Kalite	
153 R	1.5	1.5	BI20	Düz Form(Sağ Açığı)
153 R	2.0	2.0	BI40	
153 L	1.5	1.5	BI20	Düz Form(Sol Açığı)
153 L	2.0	2.0		
153 Rx	1.5	1.5	BI20	Kepçeli Form(Sol Açığı)
153 Rx	2.0	2.0		

KESME UÇ 18° SAĞ / SOL (KEPÇELİ FORM)

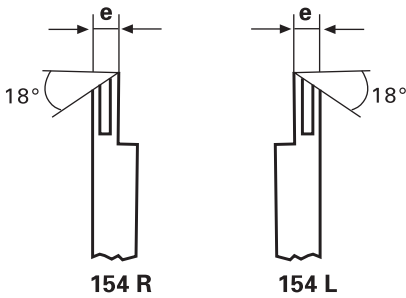

Sipariş Kodu	e	L	Kalite
154 R/L	1.5	8.0	BI20
154 R/L	2.0	10.0	

KESME UÇ 18° SAĞ VE SOL (DÜZ FORM)

Sipariş Kodu	e	L	Kalite
155 R/L	1.5	7.0	B120
155 R/L	1.8	8.0	
155 R/L	2.0	10.0	
155 R/L	2.5	10.0	
155 R/L	3.0	10.0	
155 R/L	1.5	7.0	TIN
155 R/L	1.8	8.0	
155 R/L	2.0	10.0	
155 R/L	2.5	10.0	
155 R/L	3.0	10.0	
155 R/L	1.5	7.0	B140
155 R/L	1.8	8.0	
155 R/L	2.0	10.0	
155 R/L	2.5	10.0	
155 R/L	2.5	10.0	

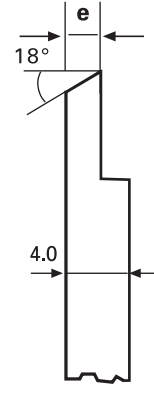

155 R

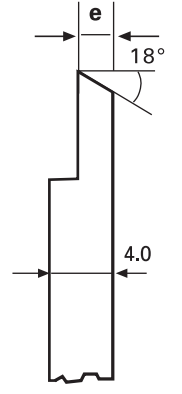

155 L

KANAL-TORNALAMA UCU 2° SAĞ / SOL (DÜZ FORM)

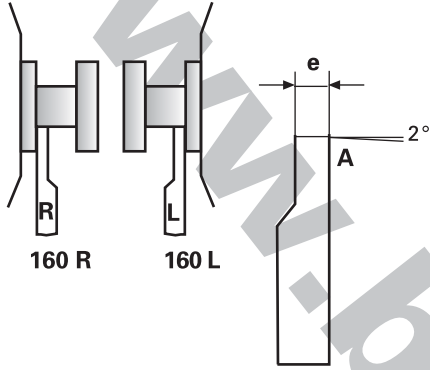

Sipariş Kodu	e	Kalite
160R/L A= 2°	1.5	BI20
	2.0	
	2.5	
160R/L A= 2°	1.5	TIN
	2.0	
	2.5	

KANAL-TORNALAMA UCU 0° (PARİSLİ FORM)

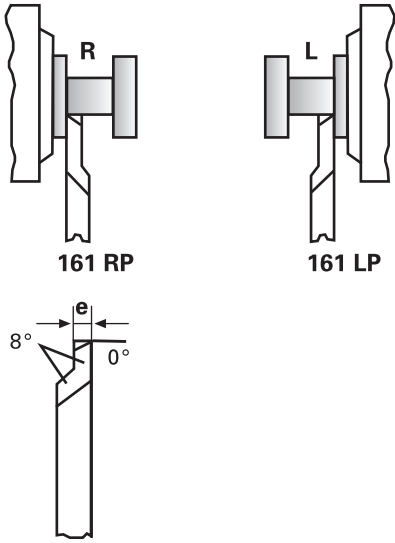

Sipariş Kodu	e	Kalite
161RP/LP	1.5	BI20 BI40
161RP/LP	2.0	
161RP/LP	2.5	
161RP/LP	3.0	TIN
161RP/LP	1.5	
161RP/LP	2.0	
161RP/LP	2.5	
161RP/LP	3.0	

TORNALAMA UCU SAĞ / SOL

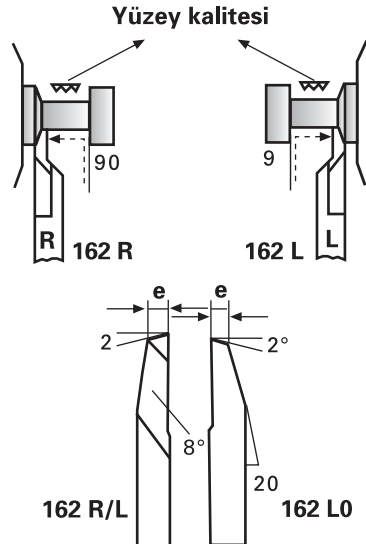

Sipariş Kodu	e	Kalite
162 R/L	1.9	BI40 TIN

Parisli Form

Sipariş Kodu	e	Kalite
162 LO	1.9	BI20

Düz Form

Kaba işlem için uygundur.

TORNALAMA UCU 2° SAĞ / SOL (DÜZ FORM)

Sipariş Kodu	e	Kalite
164R/L	4.0	BI20 BI40 TIN

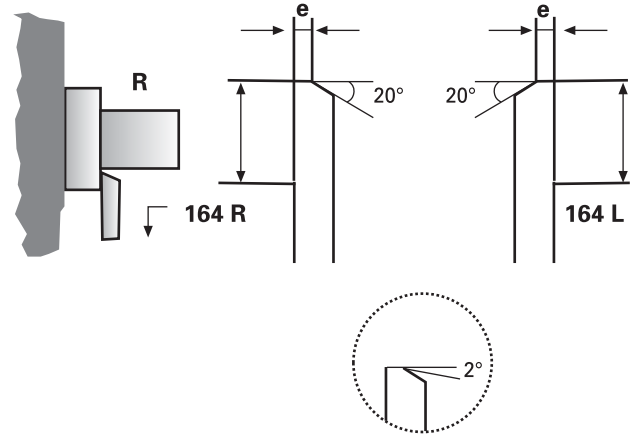

TORNALAMA UCU SAĞ / SOL (PARİSLİ FORM)

Sipariş Kodu	e	Kalite
165R/L	4.0	BI20 BI40 TIN

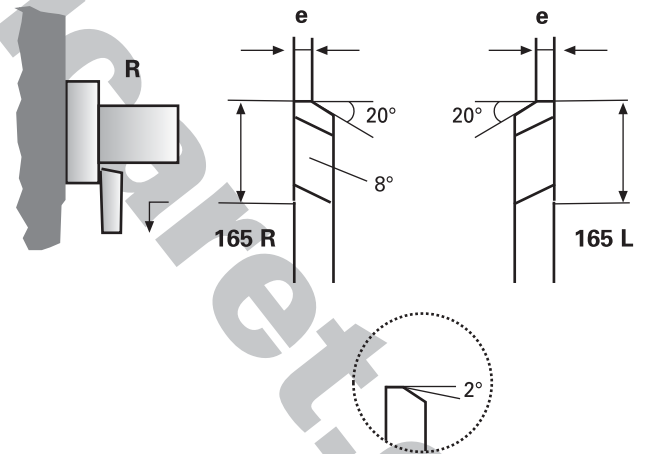

KATERLER SAĞ (250 UÇ İÇİN)

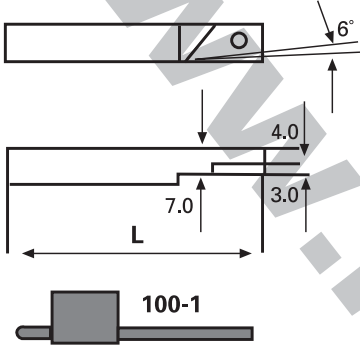

Sipariş Kodu	C	L
212R90	12 x 12	90
212R120	16 x 16	120
100-1	Torx 15	
100-2	M3.5	
100-2c	M3.5 x 7	

KESME UCU SAĞ (DÜZ FORM)

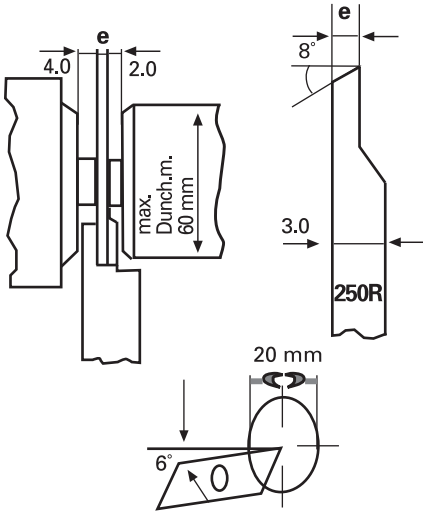

Sipariş Kodu	e	Kalite
250R	1.8	BI40
250R	2.0	
250R	1.0	BI20 TIN
250R	1.6	
250R	1.8	
250R	2.0	
250R	2.5	

KATER SAĞ

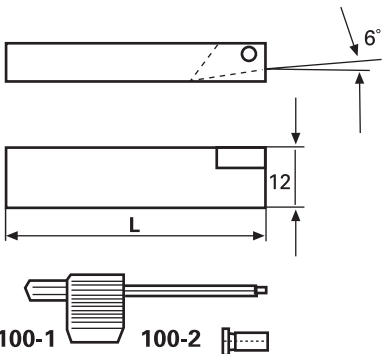

Sipariş Kodu	e	Kalite
212RS	12 x 12	90
100-1	Torx 15	
100-2	M3.5 x 9	

KATER SAĞ

Sipariş Kodu	C	L
212R-5	12 x 12	90

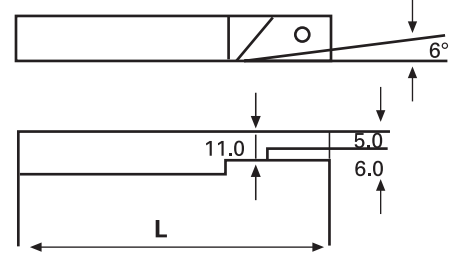

KANAL UÇLARI SAĞ (DÜZ FORM)

Sipariş Kodu	e	Kalite
260R	2.0	K10 BI20
260R	3.0	
260R	4.0	
260R	5.0	K10 BI20
260R	6.0	
260R	8.0	

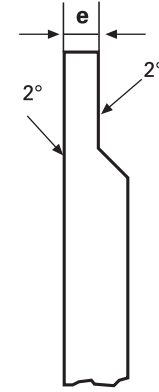

Uçları kateri sökmeden değiştirmek mümkün.

PROFİL UÇLAR SAĞ

Sipariş Kodu	e	Kalite
240R3	3.0	K10
240R6	6.0	K10

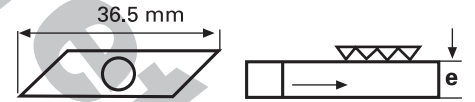

KATERLER SAĞ / SOL

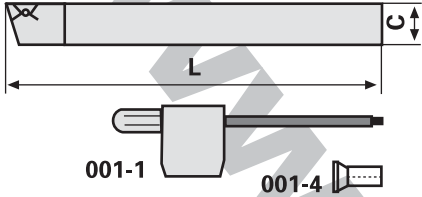

Sipariş Kodu	C	L
406L	6 x 6	124
407R/L	7 x 7	124
408R/L	8 x 8	124
410R/L	10 x 10	124
412R/L	12 x 12	124
416R/L	16 x 16	124
001-1	TORX 8	
001-4	M3 x 7.5	

PROFİL UÇLAR SAĞ / SOL

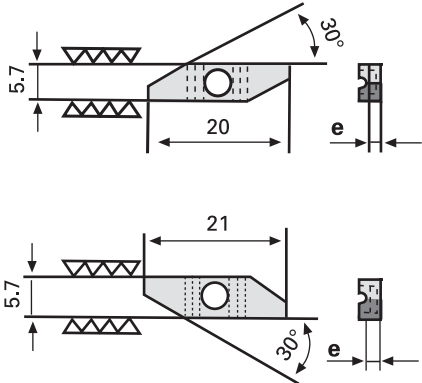

Sipariş Kodu	e	Kalite
440R/L 0.7	0.7	BI55 K20
440R/L 1.2	1.2	
440R/L 1.7	1.7	
440R/L 2.2	2.2	

KESME UÇ 18° SAĞ / SOL (DÜZ FORM)

Sipariş Kodu	e	L	Kalite
450R/L	0.8	4	BI55 BI40F
450R/L	1.0	4	
450R/L	1.2	5	
450R/L	1.5	5	
450R/L	2.0	5	

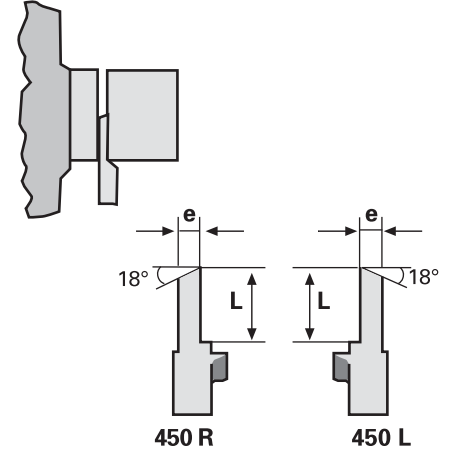

KESME UÇ 18° SOL (SAĞ KESME AÇILI-DÜZ FORM)

Sipariş Kodu	e	L	Kalite
453R	1.0	4	BI55 BI40F
453R	1.2	5	
453R	1.5	5	
453R	2.0	5	

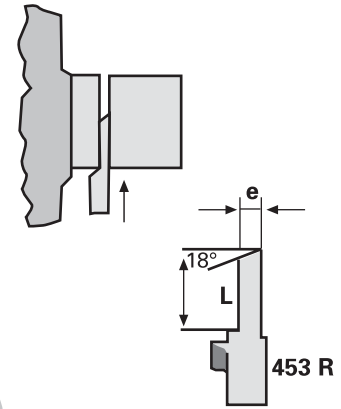

KESME UÇ 18° SAĞ / SOL (KEPÇELİ FORM)

Sipariş Kodu	e	L	Kalite
454R/L	1.0	4	BI55 BI40F
454R/L	1.2	5	
454R/L	1.5	5	
454R/L	1.8	5	
454R/L	2.0	5	

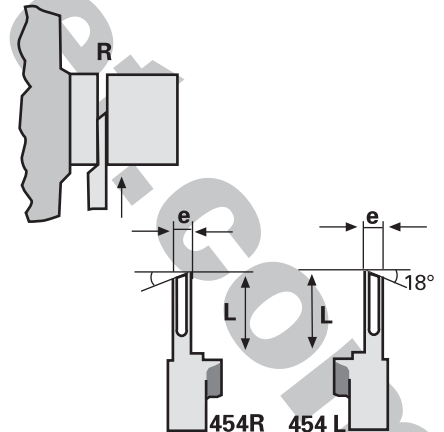

KANAL UCU SAĞ / SOL (DÜZ FORM)

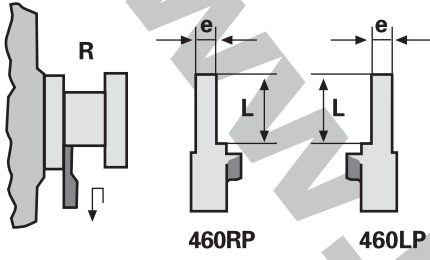

Sipariş Kodu	e	L	Kalite
460RP/LP	1.0	1.7	BI55 BI40F
460RP/LP	1.2	2	
460RP/LP	1.5	3	
460RP/LP	2.0	4	

KANAL UCU SAĞ / SOL (PARİSLİ FORM)

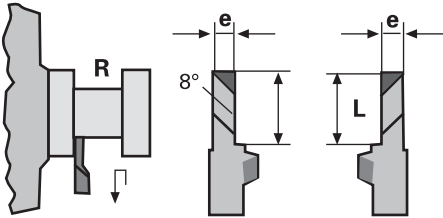

Sipariş Kodu	e	L	Kalite
461 R/L	1.0	1.7	BI55 BI40F
461 R/L	1.2	2	
461 R/L	1.5	3	
461 R/L	2.0	4	

TORNALAMA UCU SAĞ (PARİSLİ FORM)

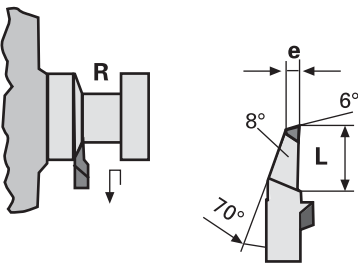

Sipariş Kodu	e	L	Kalite
462 R	0.5	3	BI55 BI40F
462 R	0.8	3	

TORNALAMA UÇ 6° SAĞ (DÜZ FORM)

Sipariş Kodu	e	L	Kalite
462RO	0.5	3	BI55 BI40F

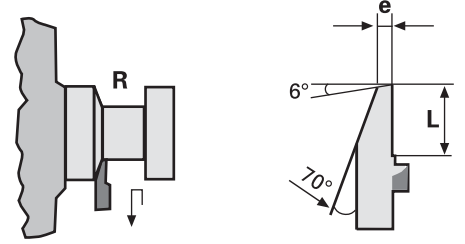

TORNALAMA UÇ 8° SAĞ / SOL (KEPÇELİ FORM)

Sipariş Kodu	e	L	Kalite
463R/L	0.5	4	BI55 BI40F

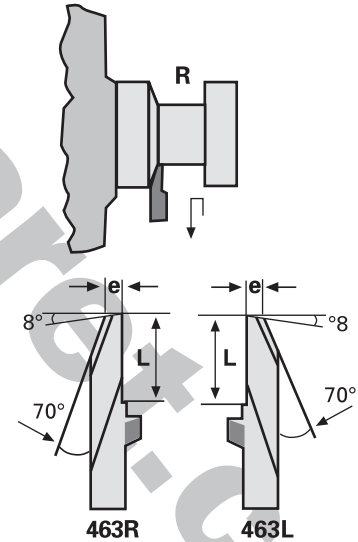

TORNALAMA UCU 2° SAĞ / SOL (DÜZ FORM)

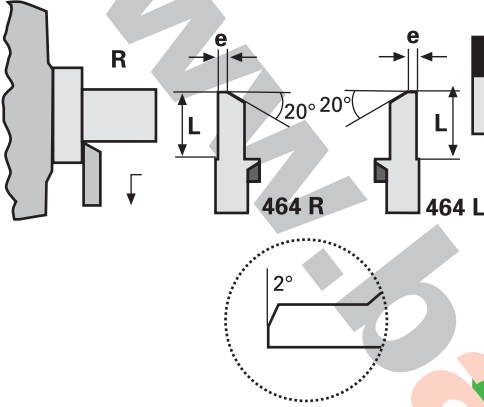

Sipariş Kodu	e	L	Kalite
464R/L	0.8	5	BI55 BI40F

TORNALAMA UCU 3° SAĞ (ÖZEL ÖLÇÜ-DÜZ FORM)

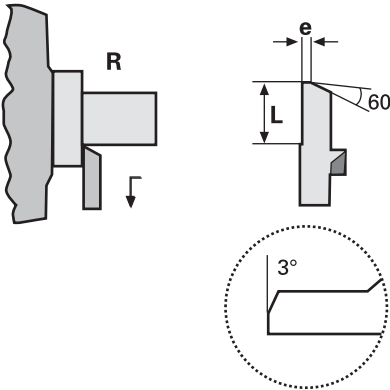

Sipariş Kodu	e	L	Kalite
468R	0.3/1	5	BI55 BI40F

TORNALAMA UCU 2° SAĞ (PARİSLİ FORM)

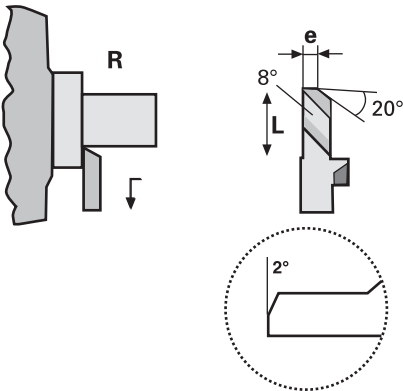

Sipariş Kodu	e	L	Kalite
465R	0.8	5	BI55 BI40F

PROFİL DİŞ AÇMA UCU SAĞ

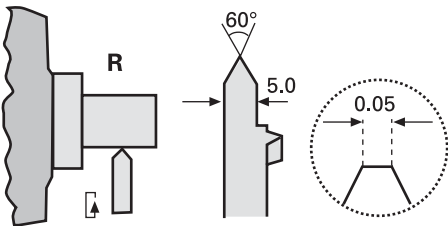

Sipariş Kodu	e	Kalite
480R	1.0	BI55 BI40F

800 LINE

8x8 Katerler İçin Kesme Uçları
R (Sağ) / L (Sol)

KESME UCU SAĞ / SOL

Sipariş	e	L	Kalite
BP850-8R1.2	1.2	6	K10 BI40U
BP850-8R1.5	1.5	7	K10 BI40U
BP850-8R2.0	2.0	8	K10 BI40U

18° Sağ
Düz Form

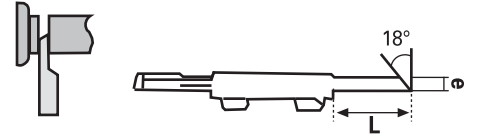

Sipariş Kodu	e	L	Kalite
BP851-8R1.2	1.2	6	K10 BI40U
BP851-8R1.5	1.5	7	K10 BI40U
BP851-8R2.0	2.0	8	K10 BI40U

15° Sağ
Kepçeli Form

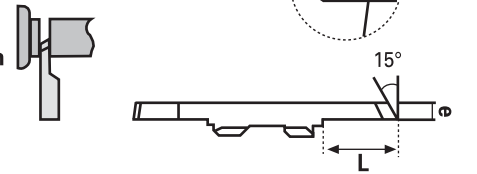

Sipariş Kodu	e	L	Kalite
BP853-8R1.2	1.2	6	K10 BI40U
BP853-8R1.5	1.5	7	K10 BI40U
BP853-8R2.0	2.0	8	K10 BI40U

12° Sol
Düz Form

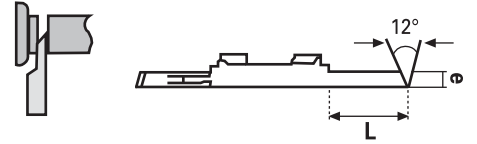

K10 = Kaplamasız
BI40U = PVD Kaplama (TiAlN)

KATERLER SAĞ / SOL

Sipariş Kodu	Katerler	Çap
BH808R	850-8R ve 851-8R için	8 x 8
BH808L	853-8R için	

Uygun Makinalar

Tornos
Tornos Deco
Citizen
Star

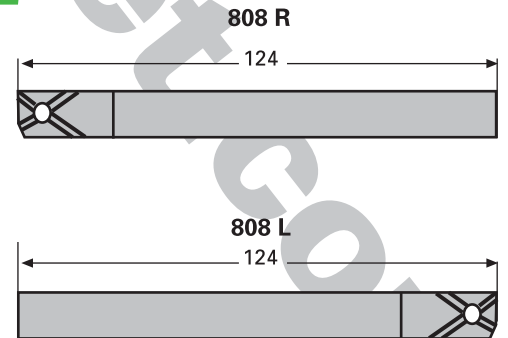

KATERLER SOL

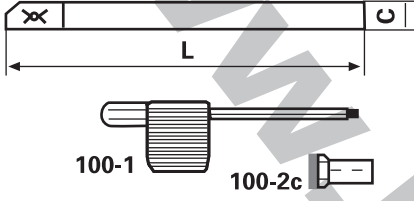

Sipariş Kodu	C	L
808L	8 x 8	124
100-1	TORX 15	
100-2c	M3.5 x 7.5	

PROFİL UÇLAR SOL

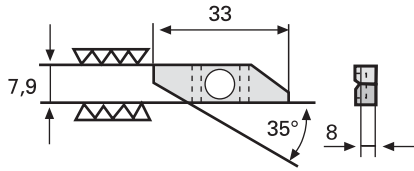

Sipariş Kodu	e	Kalite
841L 1.7	1.7	BI55
841L 2.2	2.2	
841L 2.8	2.8	

KESME UCU 18° SOL (DÜZ FORM)

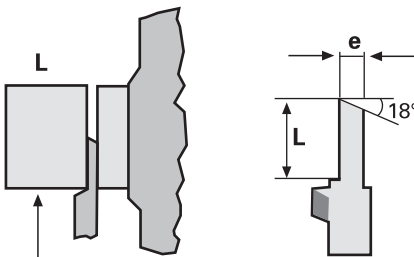

Sipariş Kodu	e	L	Kalite
855L	1.5	7.5	BI55 B140F
855L	1.8	7.5	
855L	2.0	9	

KATERLER SAĞ / SOL

Sipariş Kodu	C	L
810L/R	10 x 10	124
812L/R	12 x 12	124
816L/R	16 x 16	124
100-1	TORX 15	
100-4	M4.5 X 10	

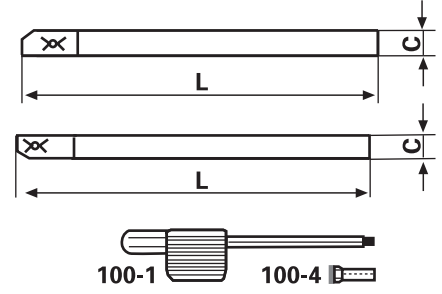

KATERLER SAĞ (İNCE)

Sipariş Kodu	C	L
812R4	10 x 10	124
812R4	12 x 12	124
812R4	16 x 16	124

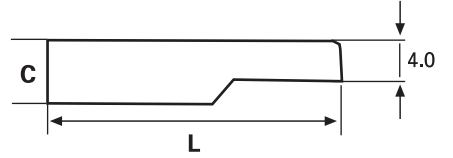

PROFİL UÇ SAĞ / SOL

Sipariş Kodu	e	Kalite
840R/L 1.7	1.7	BI55
840R/L 2.2	2.2	
840R/L 2.8	2.8	

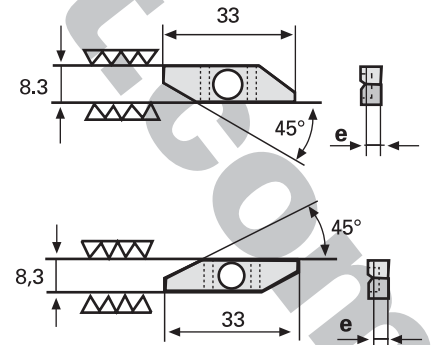

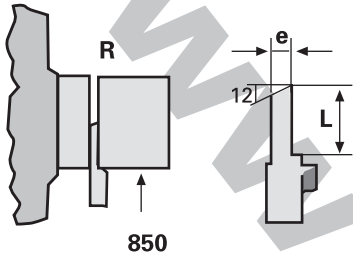

KESME UCU 12° SAĞ / SOL (DÜZ FORM)

Sipariş Kodu	e	L	Kalite
850R/L	1.0	6	BI55 BI40F
850R/L	1.5	7.5	
850R/L	2.0	10	
850R/L	2.5	10	

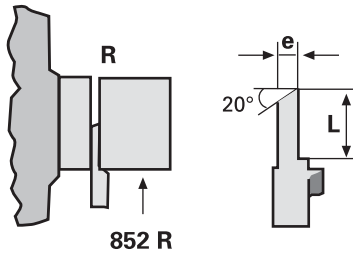

KESME UCU 20° SAĞ (DÜZ FORM)

Sipariş Kodu	e	L	Kalite
852R	1.0	6	BI55 BI40F
852R	1.2	6	
852R	1.5	7.5	
852R	2.0	10	

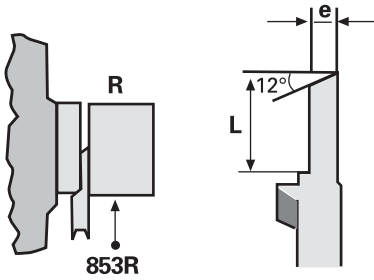

KESME UCU 12° SOL (SAĞ AÇILI-DÜZ FORM)

Sipariş Kodu	e	L	Kalite
853R	1.0	6	BI55 BI40F
853R	1.5	7.5	
853R	2.0	10	
853R	2.5	10	

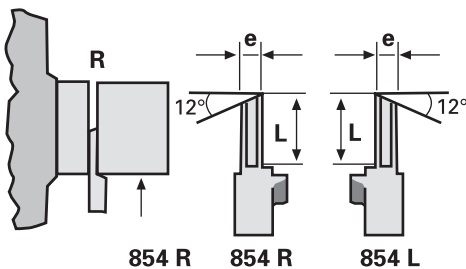

KESME UCU 12° SAĞ / SOL (KEPÇELİ FORM)

Sipariş Kodu	e	L	Kalite
854R/L	1.5	7.5	BI55 BI40F
854R/L	2.0	10	
854R/L	2.5	10	

800 LINE

Kanal ve Tornalama Uçları
R (Sağ) / L (Sol)

KANAL UÇ SAĞ / SOL (DÜZ FORM)

Sipariş Kodu	e	L	Kalite
860RP/LP	1.5	5	BI55 BI40F
860RP/LP	2.0	6	
860RP/LP	2.5	6	

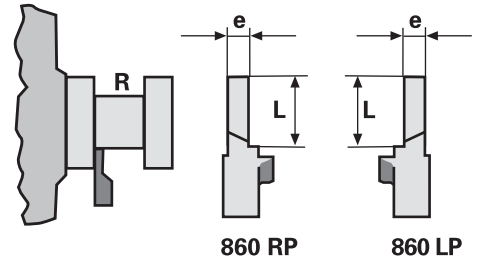

KANAL ve TORNALAMA UÇLARI SAĞ / SOL (PARİSLİ FORM)

Sipariş Kodu	e	L	Kalite
861R/L	1.5	3	BI55 BI40F
861R/L	2.0	5	
861R/L	2.5	6	

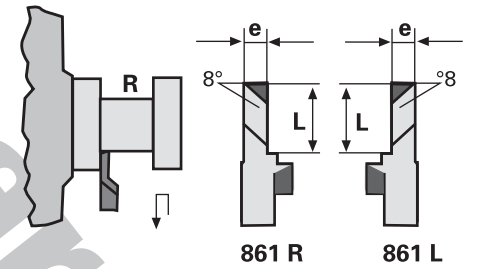

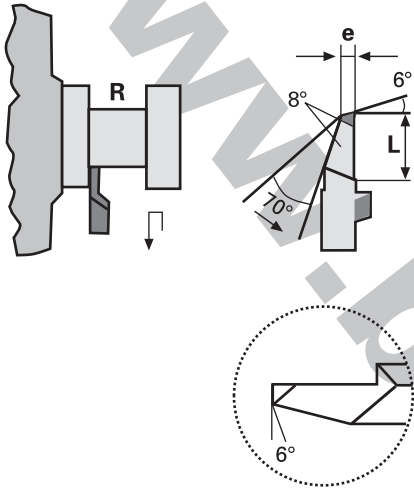

TORNALAMA UCU 6° SAĞ (PARİSLİ FORM)

Sipariş Kodu	e	L	Kalite
862R	0.5	5	BI55 BI40F
862R	1.0	5	BI55 BI40F

Kaba tornalama için uygundur.

TORNALAMA UCU SAĞ (KEPÇELİ FORM)

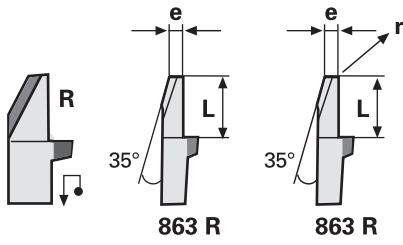

Sipariş Kodu	e	L	Kalite
863R	1.0	5	BI55 BI40F

Sipariş Kodu	e	r	L	Kalite
863R r=0,05	1	0.05	5	BI55 BI40F
863R r=0,10	1	0.10	5	BI55 BI40F

800 LINE

Tornalama ve Diş Açma Ucu
R (Sağ) / L (Sol)

TORNALAMA UCU 2° SAĞ (PARİSLİ FORM)

Sipariş Kodu	e	L	Kalite
865R	1.5	6	BI55 BI40F

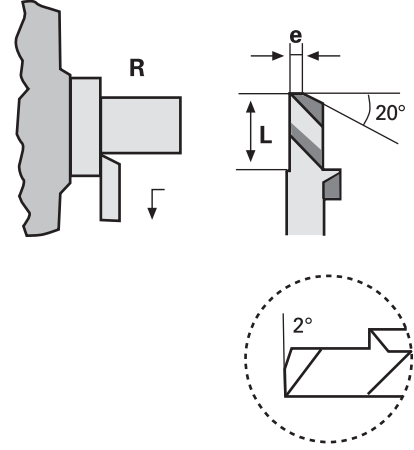

DIŞ AÇMA UCU SAĞ

Sipariş Kodu	e	Kalite
880R	1.0	BI55 BI40F

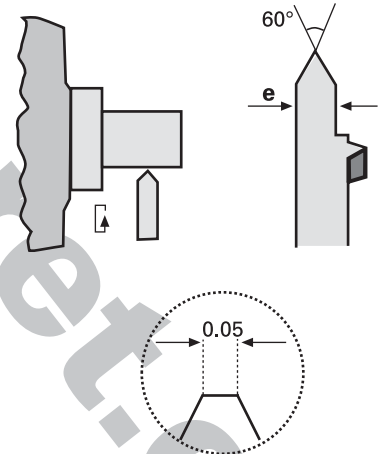

KESME UCU VE KATERLER SAĞ

Ürün Kodu		e	L	r	Kalite
BP844R1, 5BI40U	<p>Düz Form</p>	1,5	7,5	-	AITIN
BP844R2, 0BI40U		2,0	9	-	AITIN
BP842Rb1, 5BI40U	<p>Kepçeli Form</p>	1,5	7	-	AITIN
BP842Rb2, 0BI40U		2,0	7	-	AITIN
BP843Rb1, 5 - r0,1 - BI40U	<p>Kepçeli Form</p>	1,5	7	0,1	AITIN
BP843Rb2, 0 - r0,1 - BI40U		2,0	7	0,1	AITIN

Ürün Kodu		C x C	L
BH810R		10 x 10	124
BH812R		12 x 12	124
BH816R		16 x 16	124

KESME UCU VE KATERLER SOL

Ürün Kodu	Kesme Ucu Sol	e	L	r	Kalite
BP853R+1, 5BI40U	<p>Düz Form</p>	1,5	7,5	-	AITIN
BP853R+2, 0BI40U		2,0	9	-	AITIN
BP853Rb1, 5BI40U	<p>Kepçeli Form</p>	1,5	7	-	AITIN
BP853Rb2, 0BI40U		2,0	7	-	AITIN
BP853Rb1, 5 - r0,1 - BI40U	<p>Kepçeli Form</p>	1,5	7	0,1	AITIN
BP853Rb2, 0 - r0,1 - BI40U		2,0	7	0,1	AITIN

Ürün Kodu	Katerler Sol	C x C	L
BH810L		10 x 10	124
BH812L		12 x 12	124
BH816L		16 x 16	124

KANAL VE TORNALAMA UCU SAĞ (PARİSLİ FORM)

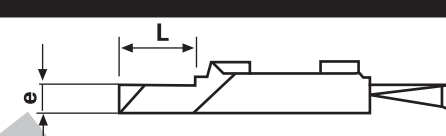
Ürün Kodu	Kanal ve Tornalama Ucu Sağ	e	L	r	Kalite
861Rb1, 5BI40U		1,5	3	-	AITIN
861Rb2, 0BI40U		2,0	5	-	AITIN

TORNALAMA UCU SAĞ (KEPÇELİ FORM)

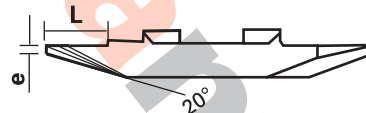
Ürün Kodu		e	L	Kalite
863Rb-20°		0,6	5	AITIN

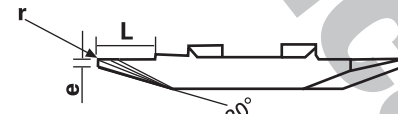
Ürün Kodu		e	L	r	Kalite
863Rb-r-20°		0,6	5	0,1	AITIN
		0,6	5	0,2	AITIN

KATERLER SAĞ

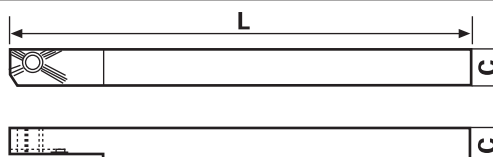
Ürün Kodu	Katerler Sağ	C X C	Kalite
BH810R		10 x 10	124
BH812R		12 x 12	124
BH816R		16 x 16	124

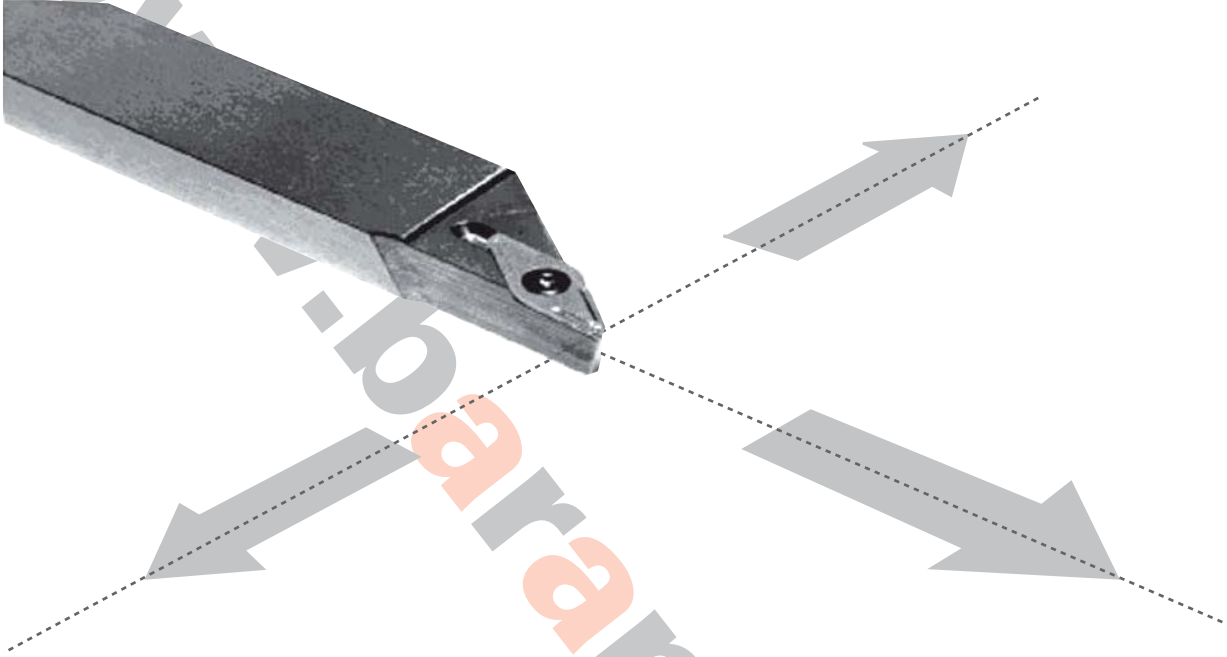

Kater ve Uçlar
Sağ / Sol

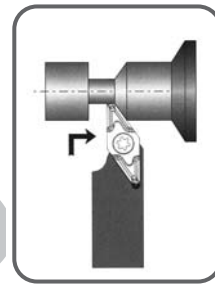
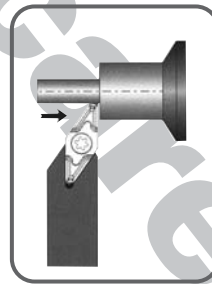
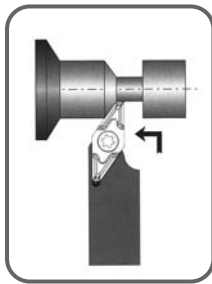
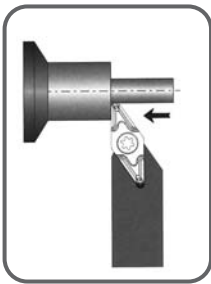

KATERLER SAĞ / SOL

Sipariş Kodu	B x H	L	S	F
SVJP L 0807	8 x 7	120	10	8
SVJP L 0808	8 x 8	120	10	8
SVJP L 1010	10 x 10	120	10	10
SVJP L 1212	12 x 12	120	10	12
SVJP L 1616	16 x 16	120	10	16
SVJP R 0808	8 x 8	120	10	8
SVJP R 1010	10 x 10	120	10	10
SVJP R 1212	12 x 12	120	10	12
SVJP R 1616	16 x 16	120	10	16
001-1	Torx 8			
001-2	M2.5x7,5			

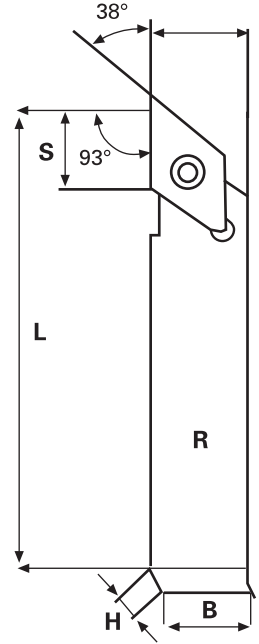

POZİTİF UÇLAR VPGT SAĞ / SOL

Sipariş Kodu	Yarı Çap (Radius)	Kalite
VPGT 10 03 ZZ FL FW	0	K10 Bl50
VPGT 10 03 008 FL FW	0.08	
VPGT 10 03 02 FL FW	0.2	
VPGT 10 03 ZZ FR FW	0	K10 Bl50
VPGT 10 03 008 FR FW	0.08	
VPGT 10 03 02 FR FW	0.2	

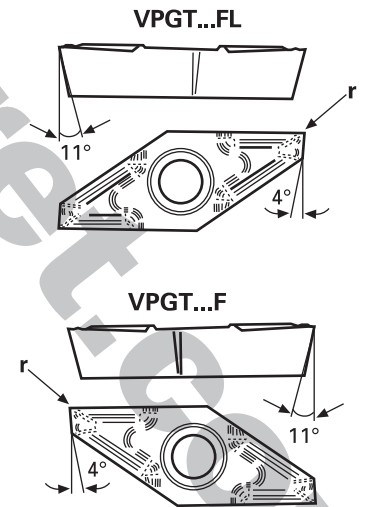

Tanımlama	Kesme Uçların Kalitesi Bileşim
K20	Kaplamasız
BI40	TIALN
BI40U	AITIN
TIN	TIN

	K20	BI40	TIN
	✓	✗	◇
	✓	✗	◇

- ✓ Mevcut
- ✗ Mevcut Değil
- ◇ İstek Üzerine

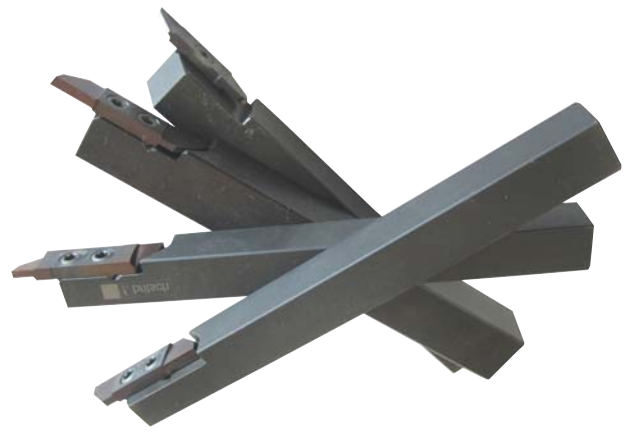

OXO Line 1000 Kullanma Alanı

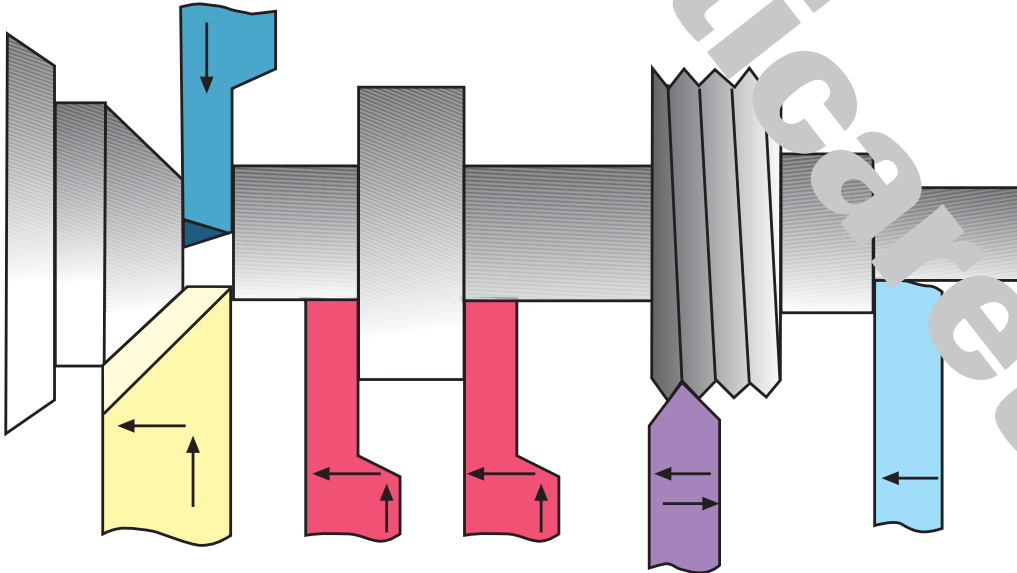

Maksimum Kesme Ø 20 mm
Maksimum Tornalama 6 mm

Sağ Kesme Uçları

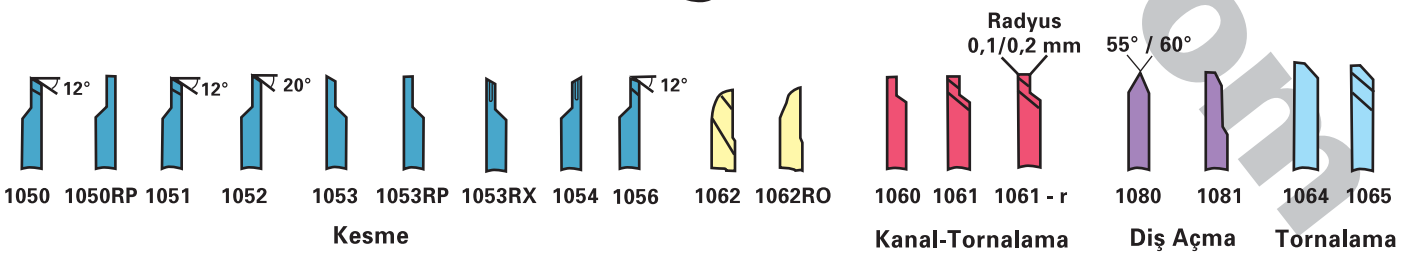

Ürün Kodu	Sağ Kater	Çap C	Uzunluk L
BH1010R		10x10	124
BH1012R		12x12	124
BH1014R		14x14	124
BH1016R		16x16	124
BH1020R		20x20	124

Ürün Kodu	Sağ Pick-up Kater	Çap C	Uzunluk L
BH1010R4		10x10	124
BH1012R4		12x12	124
BH1016R4		16x16	124

Ürün Kodu	Sol Kater	Çap C	Uzunluk L
BH1010L		10x10	124
BH1012L		12x12	124
BH1014L		14x14	124
BH1016L		16x16	124
BH1020L		20x20	124

Ürün Kodu	Sol Pick-up Kater	Çap C	Uzunluk L
BH1010L4		10x10	124
BH1012L4		12x12	124
BH1016L4		16x16	124

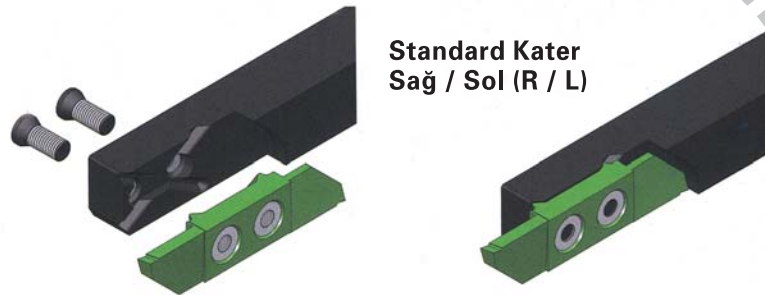

Vida M3,5 x 9

PROFİL UÇ SAĞ

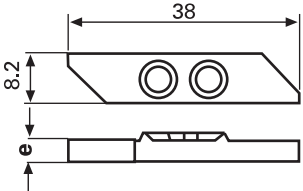
Ürün Kodu	İşlenmemiş Uç	e	K20	BI40	TIN
BP1040R3.3		3.3	✓	✓	?

KESME UÇLARI SAĞ

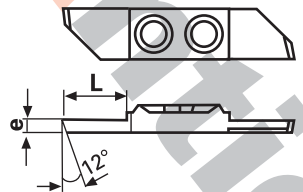
Ürün Kodu	Kesme Uç 12° (Düz Form)	e	L	K20	BI40	TIN
BP1050R1.0		1.0	5.0	✓	✓	?
BP1050R1.2		1.2	6.0	✓	✓	?
BP1050R1.5		1.5	7.5	✓	✓	?
BP1050R2.0		2.0	10.5	✓	✓	?
BP1050R2.5		2.5	10.5	✓	✓	?

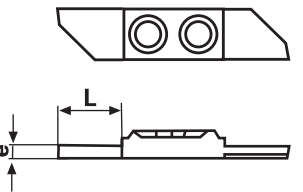
Ürün Kodu	Kesme Uç 0° (Düz Form)	e	L	K20	BI40	TIN
BP1050RP2.0		2.0	10.5	✓	✓	?
BP1050RP2.5		2.5	10.5	✓	✓	?

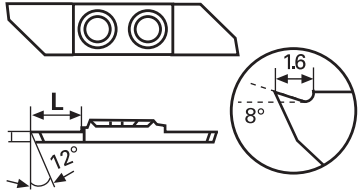
Ürün Kodu	Kesme Uç 12° (Kepçeli Form)	e	L	K20	BI40	TIN
BP1051R1.5		1.5	7.5	✓	✓	?
BP1051R2.0		2.0	10.5	✓	✓	?
BP1051R2.5		2.5	10.5	✓	✓	?

Ürün Kodu	Sağ Kesme Ucu 20° (Düz Form)	e		K20	BI40	TIN
BP1052R1.5		1.5	7.5	✓	✓	?
BP1052R2.0		2.0	10.5	✓	✓	?
BP1052R2.5		2.5	10.5	✓	✓	?

Ürün Kodu	Sol Kesme Ucu 12° (Sağ Açılı - Düz Form)	e		K20	BI40	TIN
BP1053R1.0		1.0	6.0	✓	✓	?
BP1053R1.2		1.2	6.0	✓	✓	?
BP1053R1.5		1.5	7.5	✓	✓	?
BP1053R2.0		2.0	10.5	✓	✓	?
BP1053R2.5		2.5	10.5	✓	✓	?

Ürün Kodu	Sol Kesme Ucu 12° (Sağ Açılı - Kepçeli)	e		K20	BI40	TIN
BP1053RX1.5		1.5	7.5	✓	✓	?
BP1053RX2.0		2.0	10.5	✓	✓	?

Ürün Kodu	Sol Kesme Uç 0° (Düz Form)	e	L	K20	BI40	TIN
BP1053RP2.0		2.0	10.5	✓	✓	?
BP1053RP2.5		2.5	10.5	✓	✓	?

Ürün Kodu	Sağ Kesme Ucu 12° (Kepçeli Form)	e	L	K20	BI40	TIN
BP1054R1.5		1.5	7.5	✓	✓	?
BP1054R2.0		2.0	10.5	✓	✓	?
BP1054R2.5		2.5	10.5	✓	✓	?

Ürün Kodu	Sol Kesme Ucu (Sağ Açılı Talaş Kırmalı Kepçeli Form)	e	L	K20	BI40	TIN
BP1056R1.5		1.5	7.5	✓	✓	?
BP1056R2.0		2.0	10.5	✓	✓	?
BP1056R2.5		2.5	10.5	✓	✓	?

Ürün Kodu	Kanal Ucu Sağ (Düz Form)	e	L	K20	BI40	TIN
BP1060RP1.0		1.0	3.0	✓	✓	?
BP1060RP1.5		1.5	4.0	✓	✓	?
BP1060RP2.0		2.0	5.0	✓	✓	?
BP1060RP2.5		2.5	6.0	✓	✓	?
BP1060RP3.0		3.0	6.0	✓	✓	?

Ürün Kodu	Kanal Ucu Sağ (Parisli Form)	e	L	K20	BI40	TIN
BP1061R1.5		1.5	4.0	✓	✓	?
BP1061R2.0		2.0	5.0	✓	✓	?
BP1061R2.5		2.5	6.0	✓	✓	?
BP1061R3.0		3.0	6.0	✓	✓	?

Ürün Kodu	Kanal Ucu Sağ - Köşe Radyus (Parisli Form)	e	L	r	K20	BI40	TIN
BP1061R1.5-r0.1		1.5	4.0	0.1	✓	✓	?
BP1061R1.5-r0.2		1.5	4.0	0.2	✓	✓	?
BP1061R2.0-r0.1		2.0	5.0	0.1	✓	✓	?
BP1061R2.0-r0.2		2.0	5.0	0.2	✓	✓	?
BP1061R2.5-r0.1		2.5	6.0	0.1	✓	✓	?
BP1061R2.5-r0.2		2.5	6.0	0.2	✓	✓	?
BP1061R3.0-r0.2		3.0	6.0	0.2	✓	✓	?

Ürün Kodu	Tornalama Uç Sağ (Parisli Form)	e	L	K20	BI40	TIN
BP1062R1.0		1.0	6	✓	✓	?
BP1062R2.0		2.0	6	✓	✓	?

Ürün Kodu	Tornalama Uç Sağ (Düz Form)	e	L	K20	BI40	TIN
BP1062RO1.0		1.0	5.0	✓	✓	?
BP1062RO1.5		1.5	6.0	✓	✓	?

TORNALAMA UCU SAĞ

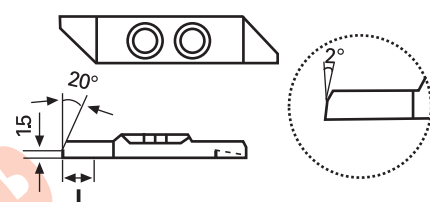
Ürün Kodu	Tornalama Ucu Sağ	L	K20	BI40	TIN
BP1064R		6.0	✓	✓	?

DİŞ ÇEKME UÇLARI SAĞ

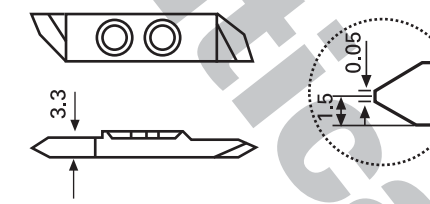
Ürün Kodu	Diş Açma Uçları 55° ve 60°	K20	BI40	TIN	
BP1080R-55°		55°	✓	✓	?
BP1080R-60°		60°	✓	✓	?

PROFİL UÇLARI SOL

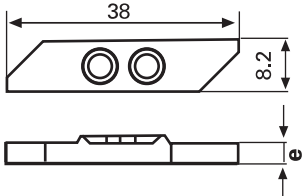
Ürün Kodu	İşlenmemiş Uç	e	K20	BI40	TIN
BP1040L3.3		3.3	✓	✓	?

KESME UÇLARI SOL

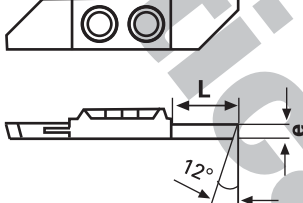
Ürün Kodu	Kesme Ucu Sol 12° (Düz Form)	e	L	K20	BI40	TIN
BP1050L1.0		1.0	6.0	✓	✓	?
BP1050L1.2		1.2	6.0	✓	✓	?
BP1050L1.5		1.5	7.5	✓	✓	?
BP1050L2.0		2.0	10.5	✓	✓	?
BP1050L2.5		2.5	10.5	✓	✓	?
BP1050L3.0		3.0	10.5	✓	✓	?

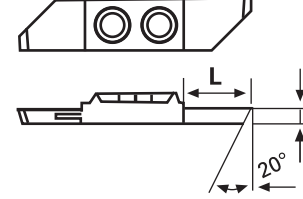
Ürün Kodu	Kesme Ucu Sol 20° (Düz Form)	e	L	K20	BI40	TIN
BP1052L1.5		1.5	7.5	✓	✓	?
BP1052L2.0		2.0	10.5	✓	✓	?
BP1052L2.5		2.5	10.5	✓	✓	?

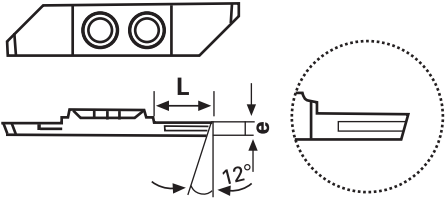
Ürün Kodu	Kesme Ucu Sol 12° (Kepçeli Form)	e	L	K20	BI40	TIN
BP1054L1.5		1.5	7.5	✓	✓	?
BP1054L2.0		2.0	10.5	✓	✓	?

Ürün Kodu	Kanal Ucu Sol (Düz Form)	e	L	K20	BI40	TIN
BP1060LP2.0		2.0	5.0	✓	✓	?
BP1060LP2.5		2.5	6.0	✓	✓	?
BP1060LP3.0		3.0	6.0	✓	✓	?

Ürün Kodu	Kanal Ucu Sol (Parisli Form)	e	L	K20	BI40	TIN
BP1061L1.0		1.0	3.0	✓	✓	?
BP1061L1.5		1.5	4.0	✓	✓	?
BP1061L1.8		1.8	4.0	✓	✓	?
BP1061L2.0		2.0	5.0	✓	✓	?
BP1061L2.5		2.5	6.0	✓	✓	?
BP1061L3.0		3.0	6.0	✓	✓	?

Ürün Kodu	Tornalama Ucu Sol (Parisli Form)	e	L	K20	BI40	TIN
BP1062L1.0		1.0	6.0	✓	✓	?
BP1062L1.5		1.5	6.0	✓	✓	?

Ürün Kodu	Tornalama Ucu (Düz Form)	e	L	K20	BI40	TIN
BH1062LO1.0		1.0	5.0	✓	✓	?
BH1062LO1.5		1.5	6.0	✓	✓	?
BH1062LO2.0		2.0	6.0	✓	✓	?

Ürün Kodu	Tornalama Ucu Sol (Düz Form)	L	K20	BI40	TIN
BH1064L		6.0	✓	✓	?

OXOline 1100 Kullanma Alanı

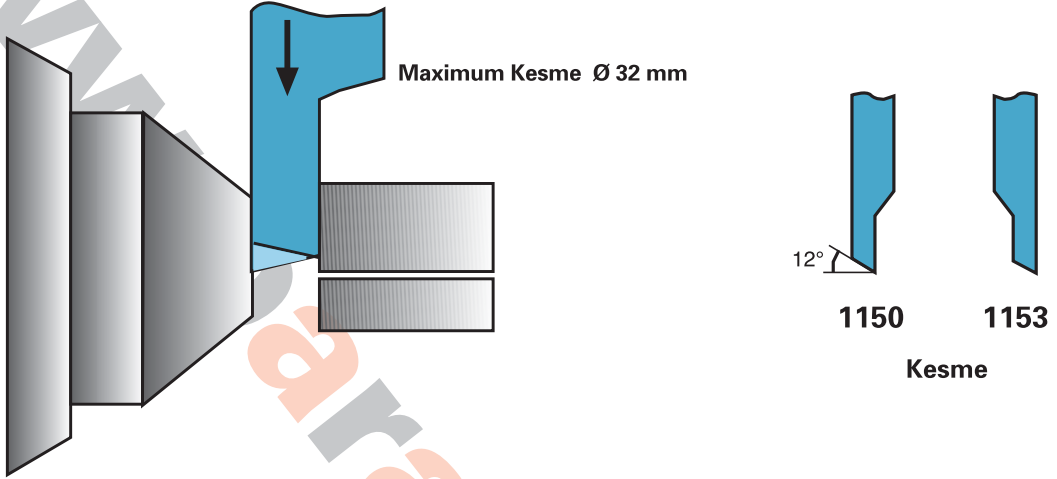

KATERLER

Ürün Kodu	Kater Sağ	Çap C	Uzunluk L
BHO1110R		10x10	124
BHO1112R		12x12	124
BHO1116R		16x16	124
BHO2020R		20x20	124

Ürün Kodu	Kater Sol	Çap C	Uzunluk L
BHO1110L		10x10	124
BHO1112L		12x12	124
BHO1116L		16x16	124
BHO1120L		20x20	124

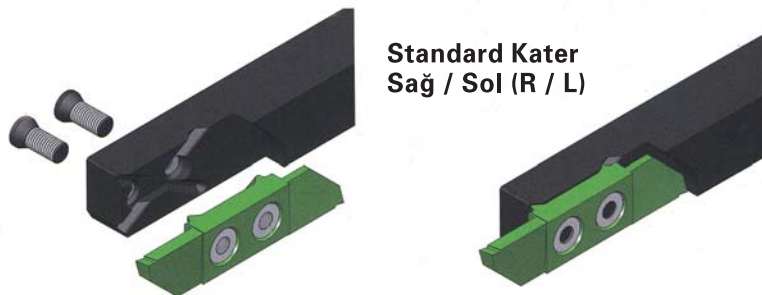

Vida M3,5 x 9

Ürün Kodu	Kesme Ucu Sağ 15° (Düz Form)	e	L	K20	BI40	BI40U	TIN
BP1150R2.0		2.0	17	✓	✗	✓	?
BP1150R2.5		2.5	17	✓	✗	✓	?
BP1150R3.0		3.0	17	✓	✗	✓	?

Ürün Kodu	Kesme Ucu Sol 15° (Sağ Açılı- Düz Form)	e	L	K20	BI40	BI40U	TIN
BP1153R2.0		2.0	17	✓	✗	✓	?
BP1153R2.5		2.5	17	✓	✗	✓	?
BP1153R3.0		3.0	17	✓	✗	✓	?

Ürün Kodu			
BHSCH100-1	Anahtar		Torx 15
BHSCH100-2	Standard tutucu için vida		M3.5 x 9

Model

AA



BL30°
BL45°



BR30°
BR45°

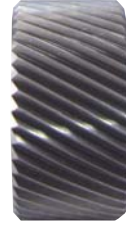

GE30°
GE45°



GV30°
GV45°



Model Açıklaması

AA : Düz Tırtıl

BL : Sol Tırtıl 30° - 45°

BR : Sağ Tırtıl 30° - 45°

GE : Erkek BaklaTırtıl 30° - 45°

GV : Dişi BaklaTırtıl 30° - 45°

Örnek Sipariş Şeması

Model	Çap	Kalınlık	Delik Çapı	Hatve
AA	10	4	4	0.5

Çap	Kalınlık mm	Delik Çapı mm	AA	BL30° BL45°	BR30° BR45°	GE30° GE45°	GV30° GV45°
8	4	4	✓	✓	✓	✓	✓
10	2	4	✓	✓	✓	✓	✓
10	3	4	✓	✓	✓	✓	✓
10	4	4	✓	✓	✓	✓	✓
12	4	4	✓	✓	✓	✓	✓
15	2	4	✓	✓	✓	✓	✓
15	4	4	✓	✓	✓	✓	✓
15	6	4	✓	✓	✓	✓	✓
15	8	4	✓	✓	✓	✓	✓
20	6	6	✓	✓	✓	✓	✓
20	8	6	✓	✓	✓	✓	✓
20	8	6/8	✓	✓	✓	✓	✓
20	10	6/8	✓	✓	✓	✓	✓
20	10	6	✓	✓	✓	✓	✓

TIRTİL KATERİ

10 X 10 - 12 X 12 - 16 X 16 - 20 X 20



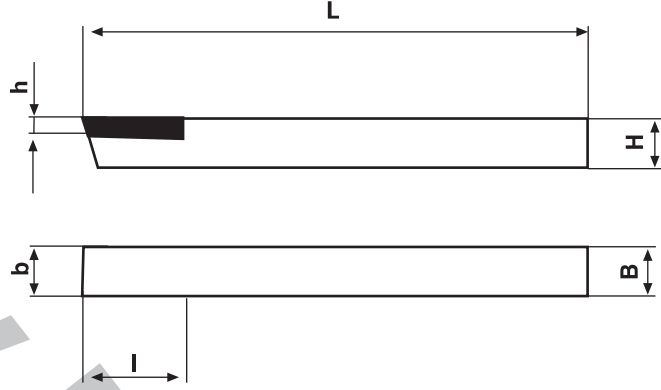

Saft B x H x L	Elmas Uç Ölçüsü b x h x l
6 X 6 X 130	6 X 2.5 X 15
7 X 7 X 140	7 X 3.0 X 15
8 X 8 X 140	8 X 3.0 X 15
10 X 10 X 150	10 X 4.0 X 16
12 X 12 X 150	12 X 4.0 X 16
14 X 14 X 150	14 X 4.0 X 16
16 X 16 X 160	16 X 4.0 X 16
20 X 20 X 160	20 X 4.0 X 16



itbaran
ticaret

www.baranticaret.com

ES SANAYİ SİTESİ 1. Sosyal Tesisleri
Dudullu/Ümraniye/ İSTANBUL
Tel: 0216 499 14 40 - 499 14 41
Faks: 0216 499 14 42
info@baranticaret.com

